

Project Title:	MINT Multimedia communications on Integrated Networks and Terminals
Document Type:	Public

Date:	February 1998
Title of Document:	DVB-T and DMB in Mobile Environments
Source:	AG3 (Transmission concepts), Task Force DVB-DMB
Authors:	R. Burow (T-Berkom), K. Fazel (DLR), P. Hoehner (DLR), O. Klank (DTB), H. Kussmann (Bosch), P. Pogrzeba (T-Berkom), P. Robertson (DLR), and M. J. Ruf (Bosch)
Editors:	K. Fazel, P. Robertson

Summary:	<p>Mobile multimedia services (digital TV, sound, data, etc.) may become an important feature of terrestrial networks for a variety of applications. One possible scenario to offer digital TV services for mobile and portable receivers with a large coverage area is to use the DAB system with an additional outer error correcting code that offers a capacity of about 1.2-1.6 Mbit/s using a bandwidth of 1.536 MHz. This system is called Digital Multimedia Broadcasting (DMB). An alternative/complementary solution might be based on the use of the DVB-T specifications that may allow much higher data rate (more than 5 Mbit/s) using an 8-MHz UHF-channel (about 5 times larger than DMB). Although, the DVB-T specifications were designed for fixed/portable reception, but some of its rugged modes such as QPSK (resp. 16-QAM) with strong inner code as DMB and 2k sub-carriers with strong inner code might allow (resp. limited or the same coverage with higher transmitted power) mobile reception of TV-services.</p> <p>The aim of this report is to analyse through theoretical investigations, computer simulations, laboratory tests and field trials, the behaviour/limits of the DVB-T specifications in mobile environments, where high Doppler frequency, deep-fading and shadowing are the most known dominant factors that decrease the system performance. The results of this study will allow us to discuss and analyse the performance of the DMB and the DVB-T systems in more detail.</p> <p>Following the analysis, it seems that the Doppler shift, at the expense of a higher SNR, especially for a QPSK (resp. 16-QAM with rate 1/2) constellation is not the fundamental limitation of the DVB-T specifications, as often believed. Rather, it is the lack of time interleaving that may pose some problems in mobile environments.</p>
-----------------	--

MINT is a research project funded by the German Ministry of Education, Science, Research, and Technology (BMBF).

Contents

1 INTRODUCTION	3
2 DVB-T PERFORMANCE IN MOBILE RECEPTION	5
2.1 Frame Structure	5
2.2 Channel Estimation in the Presence of High Doppler Frequency	6
2.2.1 Theoretical Analysis	6
2.2.2 Simulation Results	11
2.3 Laboratory Measurements	21
2.4 Synchronisation Issues	25
2.5 Results of Field Trials	27
2.5.1 Itineraries and Measurements:	27
2.5.2 Evaluation of Measurements	29
2.5.3 16-QAM and 64-QAM Tests	30
3 PERFORMANCE OF DIGITAL MULTIMEDIA BROADCASTING (DMB)	32
3.1 Outer Coding	32
3.2 Synchronisation of MPEG TS-packets with Common Interleaved Frames	33
3.3 Inner Convolutional Coding	33
3.4 Simulation results	34
3.5 System Discussion	38
3.5.1 Guard Interval:	38
3.5.2 Frequency Interleaving:	38
3.5.3 Time Interleaving:	38
3.5.4 Synchronisation:	39
4 DISCUSSION OF RESULTS	40
5 CONCLUSIONS	43
6 LIST OF ABBREVIATIONS	44
7 REFERENCES	45

1 Introduction

Digital multiprogramming TV services via satellite and cable are becoming reality in Europe. Both, satellite and cable transmission media will offer a very high capacity that in addition give the facilities of new data broadcasting, including multimedia services. In order to maintain their competitiveness, the terrestrial analogue VHF/UHF broadcasting networks must evolve and exploit the benefits of digital technologies.

Within the DVB-project, the specifications of the DVB-T have been finalised by the TFSC and are submitted to ETSI [1]. In these specifications the aspects of digital multiprogramming TV for fixed reception/portable got a great importance. The digital terrestrial broadcasting systems may allow basically terrestrial networks to compete with satellite and cable in terms of picture quality and program quantity.

However, considering the higher operational efforts and maintenance costs of terrestrial networks compared to satellite and cable, it is obvious that in order to preserve its competitiveness/complementary, terrestrial broadcasters have to offer new services according to their technical characteristics: Regional, local services and portable-/mobile-/indoor-reception that will be possible only with the high power of terrestrial networks.

Mobile multimedia services (digital TV, sound, data, etc.) may become an important feature of terrestrial networks for a variety of applications, covering hand-held "Watchman" receivers and TV receivers installed in vehicles, e.g. cars, busses and trains.

The DAB system using the VHF- or the L-Band is originally designed for mobile reception of audio signals and offers about 1.5 Mbit/s useful data rate capacity in an 1.536 MHz channel [2]. The system is fully specified by ETSI and will soon be operational in most countries. Through different pilot-projects, the DAB system has been tested on an European level that will be successful without doubt.

One possible scenario to offer digital TV services for mobile and portable receivers with a large coverage area is to use the DAB system with an additional outer error correcting code. This system will be called Digital Multimedia Broadcasting (DMB) in the following [3-6]. Depending upon the system robustness (channel coding redundancy) and the composition of the multiplexing, the available data rate for TV broadcasting will be in the order of 1.2-1.6 Mbit/s. For more detail on the DMB system, the reader is referred to [6].

An alternative/complementary solution might be based on the use of the DVB-T specifications that can offer much higher data rate (more than 5 Mbit/s) using an 8-MHz UHF channel. Although, the DVB-T specifications were defined for fixed/portable reception, but some of its rugged modes such as QPSK (resp. 16QAM) with strong inner coding (as DMB) for high error correcting capability and 2K sub-carriers might allow (resp. limited or the same coverage with higher transmitted power) TV services for mobile reception. Indeed, if a QPSK constellation is used, the DMB and the DVB-T may provide relatively similar spectral efficiency

The aim of this report is to analyse through theoretical investigations, computer simulations, laboratory tests and field trials, the behaviour of the DVB-T specifications in mobile environments, where high Doppler frequency, fading and shadowing are the most known dominant factors that decrease the system performance. This study, by using the simulation results, may allow us to discuss and to analyse the performance of both systems, i.e. the DMB and the DVB-T in mobile reception conditions.

The report is organised as follows. In Chapter 2 the DVB-T system performance for mobile reception has been analysed. This study includes the behaviour of the channel estimation technique in the presence of high Doppler frequency (up to 200 Hz) and synchronisation issues. The Digital Multimedia Broadcasting system and its performance are described in detail in Chapter 3. Finally in Chapter 4 the results of both systems, i.e. DVB-T and DMB are discussed and further investigations needed for this study are summarised.

It has to be noticed that for all theoretical investigations and computer simulations, the following parameters have been taken into account:

- Carrier-Frequency: VHF and UHF bands, i.e. from 240 MHz up to 870 MHz,
- Speed of vehicles: up to 120 km/h for bus (max. Doppler freq. 27 Hz and 97 Hz at 240- and 870 MHz, resp.) and up to 240 km/h for cars (max. Doppler freq. of 53 Hz and 193 Hz at 240- and 870 MHz, resp.),
- Profiles: GSM, DAB, and Two ray channel,
- Constellation, code rates: QPSK, $r=1/2$ (~ 5 Mbit/s) and 16 QAM, $r=1/2$ (~ 10 Mbit/s) and $r=2/3$ (~ 13 Mbit/s),
- Number of carriers: 2 K / 8 K,
- Guard-time: $T_g = T_s/4$.

2 DVB-T Performance in Mobile Reception

The DVB-T specifications are mainly based on the use of a powerful concatenated channel coding (inner convolutional code and outer Reed-Solomon code) with different modulation constellation choices (from QPSK up 64-QAM), frequency interleaving (but no time interleaving), different guard time values and a sophisticated frame-structure with well distributed pilot-symbols [1]. The DVB-T signal will be transmitted in VHF/UHF channels with frequency spacing of 7/8 MHz.

In this part of the document after a short overview of the DVB-T frame structure, some theoretical analysis and the results of computer simulations of channel estimation in the case of high Doppler frequency are given. The results of various laboratories tests and field trials carried out by Deutsche Telekom Berkom will be also given in this part.

2.1 Frame Structure

Knowledge of the frame structure is important in order to determine the performance of the channel estimation as well as the synchronisation technique. Naturally, it is also needed to design the filters used in the channel estimator. We shall define a cell to mean a unit in time and frequency, where a time unit is the OFDM symbol duration and the frequency unit is the OFDM sub-carrier spacing. Cells either contain data, scattered pilots, continual pilots or TPS symbols. For channel estimation, we are only interested in the scattered pilots, although a sophisticated channel estimator might use the TPS and continual pilots also (especially at the frequency edges that are bounded by continual carriers at K_{min} and K_{max}). For more information concerning the frame structure, refer to the ETSI document [1].

See Figure 2-0 for an illustration of a portion of the frame structure for DVB-T. Only scattered pilots (boosted by a factor of 16/9 in power or 4/3 in amplitude) are shown. The grid pattern is diagonal and has these important characteristics:

- There are pilots in every symbol, although there is an offset of 3 carriers between pilots of neighbouring symbols. Pilots on the same carrier are sent on every fourth symbol.
- There are pilots on every third carrier, although there is an offset of 1 symbol.
- Due to the diagonal grid structure, the sampling theorem allows three general cases of channel characteristics: 1) a moderate delay spread together with moderate Doppler spread; 2) a high Doppler spread together with a low delay spread; 3) a low Doppler spread together with a high delay spread.
- A rule of thumb applied to the spacing of pilots in time (every four symbols when they are on the same carrier) can be used to calculate the maximum Doppler frequency that can be tolerated -according to the sampling theorem- given just a time domain filter. For 2K carriers, this is $1/(2 \times 4 \times 280 \text{ us}) \cong 445 \text{ Hz}$. However, many taps for the interpolation filter would be required to estimate such high Doppler rates.
- The boosting in power reduces the estimation error without bandwidth expansion.

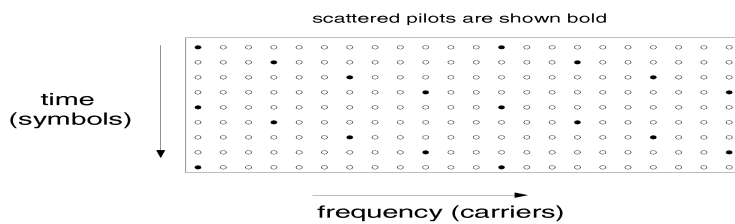

Figure 2-1 An excerpt of the DVB-T frame structure showing scattered pilots' positions in time and frequency.

2.2 Channel Estimation in the Presence of High Doppler Frequency

2.2.1 Theoretical Analysis

The performance and design of two dimensional Wiener filtering for channel estimation applied to OFDM has been presented in [7]. Given a certain sampling grid (i.e. frame structure with pilots) the optimal filter can be designed for a certain channel. The filter can be either a true two dimensional FIR filter, or two cascaded one dimensional FIR filters. Since the channel is not known completely at the time of the filter design, and because it is not practical to adaptively recalculate the filter coefficients during reception, a worst-case channel can be assumed while designing the filter; it was shown in [7] that this mismatch results in only a small degradation as long as the sampling theorem is fulfilled by the filter, i.e. the maximal channel changes lie within the filters' transfer function.

In these evaluations, a two dimensional filter with ten taps in total was simulated, although the filter coefficients as well as the pilot grid points used in the filter will vary depending on which data cell is to be channel-estimated. Note that the ten pilots' positions which are used to estimate the channel at each data cell will be different for each data cell because of their relative position to the data cell: the selection technique in the design process will choose pilots close to the data cell in question. The regular grid structure limits the number of possibilities though, because of its periodicity. All of the necessary filter coefficients (10 per data cell) along with the positions of the pertinent pilots are pre-computed and stored in the receiver. We have assumed that the maximal echo duration is equal to the guard interval duration T_g , and that the OFDM signal is time shifted to the left by $T_g / 2$ (this process is sometimes called re-rotation because it can be done in the frequency domain by rotation with a phase increment).

We have designed and simulated two different 10 tap filter sets: the first designed for a maximum Doppler of $f_{d,design} = 200$ Hz, the second for 400 Hz. In both cases, a guard interval of $T_g = T_s/4 = 56$ μ s was assumed (for 2K carriers, of course). The analysis were done with the following parameters:

- GSM channel: Hilly Terrain (see Table 2.1). Doppler frequencies: $f_{d, max} = 0$ Hz, 27 Hz, 53 Hz, 97 Hz, 193 Hz, 290 Hz and 390 Hz. Filters designed for 200 Hz and 400 Hz.

- Two paths channel of equal strength, 50 us apart. Doppler frequencies: f_d , max=0 Hz, 53 Hz and 193 Hz. Filter designed for 200 Hz.

The estimation mean square error (MSE) of the channel estimator was simulated. Edge effects were not taken into account, for the sake of simplicity (in reality there is no edge effect in time, only in frequency, at the edges of the OFDM band). The results are shown in Figures 2-1, 2-2 and 2-3. The results can be interpreted as follows:

- For a filter with a 200 Hz maximum assumed Doppler, The MSE does not deteriorate until the actual maximal Doppler rate is close to the limit of 200 Hz. Even at 193 Hz, the degradation to 0 Hz is only a factor of 2 in MSE. The curves show no visible floor up to 20 dB SNR.
- For the 400 Hz filter, the lower actual Doppler rate cases suffer a slight loss compared to the 200 Hz filter, because the filter is wider and collects more noise. However, Doppler rates of up to 290 Hz can be tolerated, close enough to our rule of thumb outlined earlier.
- The two path case performs more or less exactly the same as the HT case. This is important since the two tape case is seen as a critical one. Furthermore, it is evidence that this channel estimator does not achieve high Doppler tracking ability at the cost of insufficient frequency domain accuracy (i.e. capability of handling large delay spreads).

Since we can approximate the estimation error as additional noise, we can compute the overall SNR degradation $Degr$ due to channel estimation as follows:

$$Degr = SNR + 10 \log_{10} \left\{ MSE + 10^{-\frac{SNR}{10}} \right\}$$

Here, SNR is the operating SNR in dB as shown on the x-axis of each figure, and MSE is the estimation error in linear notation, i.e. the power of the noise affecting the channel estimate. The results of this computation are shown in Figures 2-4 and 2-5. These figures are of more direct practical use, since they allow us to predict the SNR loss that we will incur at a certain operating SNR, e.g. for QPSK or 16-QAM with codes rates of $\frac{1}{2}$ and $\frac{2}{3}$ respectively. Note here that the degradation would go to infinity if the MSE flattens out to a floor even for high SNR, because no amount of channel improvement will reduce this residual error.

- The degradation for QPSK with rate $r = 1/2$, where we expect the SNR to be about 7dB (Rayleigh), is less than 2 dB compared to perfect channel estimation for Doppler rates up to 97 Hz. This applies to the 200 Hz filter.
- For the 400 Hz filter and QPSK, the degradation is less than 3 dB up to 290 Hz Doppler rate.
- For 16-QAM with rate $r = 2/3$ (resp. $\frac{1}{2}$), where we expect the SNR to be about 16 dB (resp. 13 dB), the degradation values are 2 dB and 3.5 dB, again for the 200 and 400 Hz filters and the same range of tolerated Doppler rates as for QPSK.
- In all cases, the degradation compared to zero Hz Doppler rate is less than 1 dB, as long as the 400 Hz filter is used when the Doppler is greater than 200 Hz.

- For a Doppler rate of 193 Hz, it is still better to use the 200 Hz filter, even though we loose 2 to 3 dB compared to perfect channel estimation.

In real world applications, a two dimensional filter might be replaced by two cascaded one dimensional filters. It was the aim of this section to demonstrate that a reasonable filter complexity specifically designed for mobile reception (10 taps per data cell, not 10x10=100 taps!) will allow channel estimation of DVB-T signal even for very high Doppler rates, and despite echoes that occupy nearly the entire guard interval. Further work is needed to evaluate the performance of other filters.

However, it should be noticed that the above SNR-degradation figures can not be translated directly to the SNR-loss for a given BER. Especially in high Doppler-frequencies the lack of time interleaving will degrade much more the overall performance of the system.

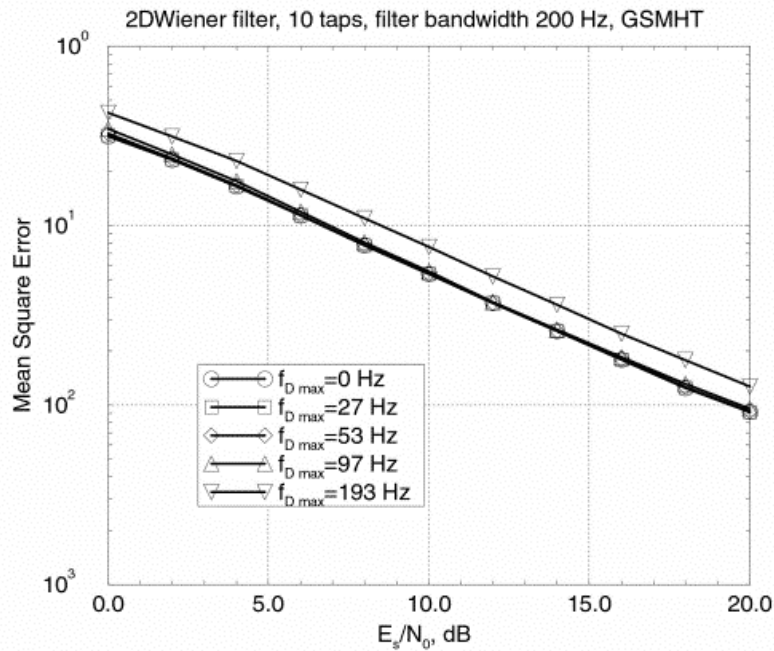

Figure 2-2 Channel GSM HT. 200 Hz filter.

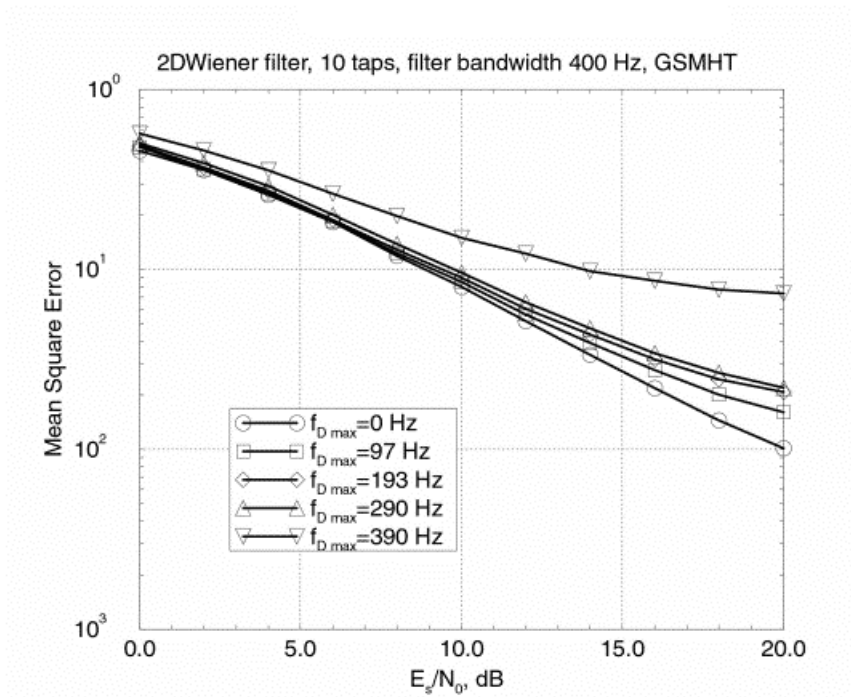

Figure 2-3 Channel GSM HT . 400 Hz filter.

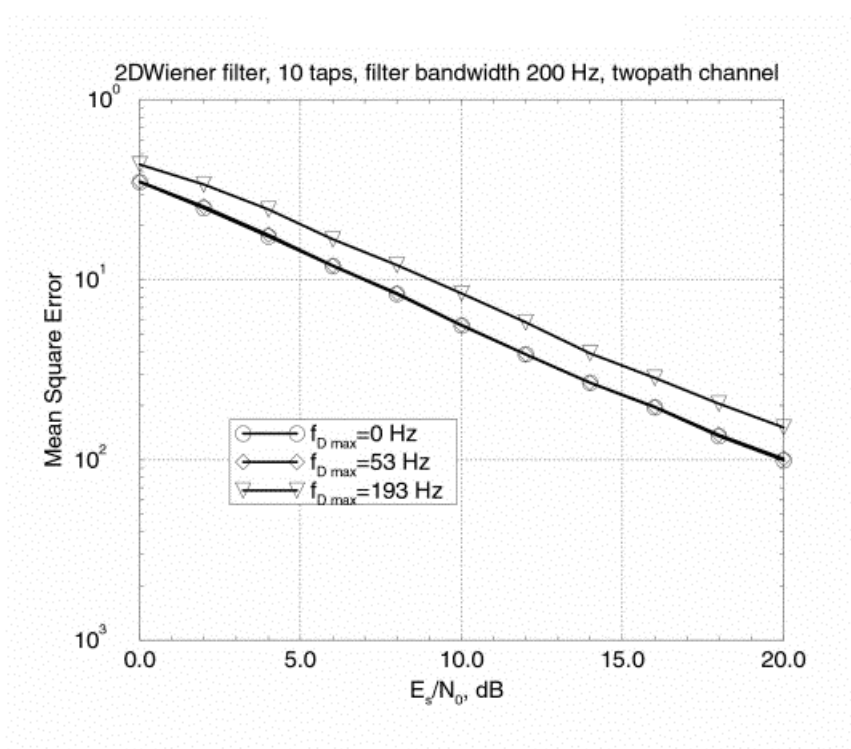

Figure 2-4 Channel: two path. 200 Hz filter

Figure missing from input document

Figure 2-5 Channel: GSM HT. 200 Hz filter.

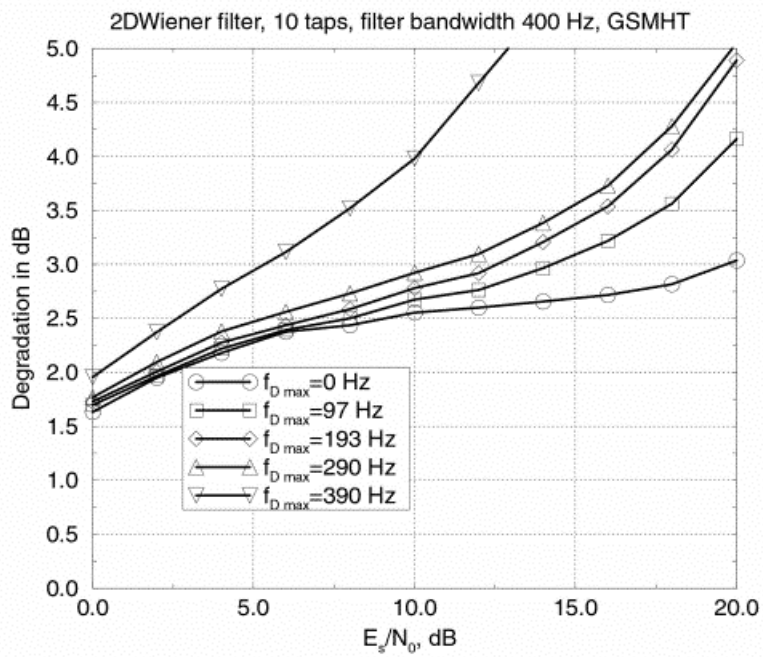

Figure 2-6 Channel: GSM HT. 400 Hz filter.

2.2.2 Simulation Results

In order to solve the question if the DVB-T system is suited for mobile reception, many simulations were made to get an idea of the performance of the system in a fading multipath channel with high Doppler shifts resulting especially from the receiver velocity. For a typical multipath propagation the transmitted electromagnetic wave will be received not only via the direct path between transmitter and receiver but also via a range of paths with different delay times resulting from reflections, diffraction and scatter in the environment. In a mobile reception the interference of these signals is time variant and depends on a very complex coherence. Therefore, a statistical model is used to simulate the transmission channel.

As a worst case, it will be supposed, that no direct signal component reaches the receiver and the Doppler power spectrum is the spectrum of an ideal isotropic distribution of the incident angles (Jakes spektrum). So the typical Rayleigh channel was considered and the channel transfer function was simulated using the Monte Carlo method. The channel impulse response of the phase modulation fading simulator can be written as [8]

$$f(\mathbf{t}, t) = \lim_{N \rightarrow \infty} \frac{1}{\sqrt{N}} \sum_{n=1}^N \exp(j(\Theta_n + 2\pi f_{Dn} t)) \cdot \mathbf{c}(\mathbf{t} - \mathbf{t}_n) \quad (2.2.2.1)$$

In this equation Θ_n , τ_n and f_{Dn} are continuous random numbers. Θ_n is the null phase of each individual echo, τ_n is the delay and f_{Dn} the Doppler frequency. For this model the null phase is uniformly distributed.

The model is statistically completely determined by the scattering function.

The used scattering functions for typical multipath reception, which are necessary to design the right statistical distribution are shown in Table 1. These scattering functions were specified in COST 207 and EUREKA 147.

Profile:	area, scattering function
P1	GSM, typical case for rural area $\exp(-9.2\tau/\mu\text{s})$ for $0 < \tau < 0.7\mu\text{s}$
P2	GSM, typical case for urban area $\exp(-\tau/\mu\text{s})$ for $0 < \tau < 0.7\mu\text{s}$
P3	GSM, typical bad case for hilly urban $\exp(-\tau/\mu\text{s})$ for $0 < \tau < 5\mu\text{s}$ $0.5 \exp(5 - \tau/\mu\text{s})$ for $5\mu\text{s} < \tau < 10\mu\text{s}$
P4	GSM, typical case for hilly terrain $\exp(-3.5\tau/\mu\text{s})$ for $0 < \tau < 2\mu\text{s}$ $0.04 \exp(15 - \tau/\mu\text{s})$ for $15\mu\text{s} < \tau < 20\mu\text{s}$
P5	DAB hilly terrain I $\exp(-3\tau/\mu\text{s})$ for $0 < \tau < 2.3\mu\text{s}$ $0.25 \exp(15 - 0.5\tau/\mu\text{s})$ for $30\mu\text{s} < \tau < 42\mu\text{s}$

Profile:	area, scattering function
	$0.17 \exp.(80 - \tau/\mu\text{s})$ for $80\mu\text{s} < \tau < 86\mu\text{s}$
P6	DAB hilly terrain II
	$\exp.(-3\tau/\mu\text{s})$ for $0 < \tau < 2.3\mu\text{s}$
	$0.12 \exp.(4 - 0.2\tau/\mu\text{s})$ for $20\mu\text{s} < \tau < 45\mu\text{s}$
	$0.3 \exp.(60 - 1.5\tau/\mu\text{s})$ for $40\mu\text{s} < \tau < 42\mu\text{s}$

Table 1: Used scattering functions as specified in COST 207 and EUREKA 147

For the following simulations, four fixed values of the maximum Doppler frequency have been considered:

- $f_{dmax} = \pm 27$ Hz, which corresponds to a receiver velocity of 120 km/h at 240 MHz carrier-frequency
- $f_{dmax} = \pm 97$ Hz, which corresponds to a receiver velocity of 120 km/h at 870 MHz carrier-frequency
- $f_{dmax} = \pm 53$ Hz, which corresponds to a receiver velocity of 240 km/h at 240 MHz carrier-frequency
- $f_{dmax} = \pm 193$ Hz, which corresponds to a receiver velocity of 240 km/h at 870 MHz carrier-frequency

The complete DVB-T transmission system, as specified in the ETS 300 744, was simulated and the bit-error-rate (BER) after the Viterbi decoder was obtained. To get a reliable statistic, a sufficient amount of errors and changes of the channel have to be simulated. So the simulated physical time was chosen to be 100 times longer than the correlation time of the channel process, which can be derived from the Doppler frequency. Therefore, the multiplication of the net bit data rate and the reciprocal Doppler frequency results in the necessary data amount, which has to be simulated. All calculations are floating point arithmetic except for the derivation of the reliability information for the Viterbi decoder, but this will be considered in detail later.

Considering the fact that, for the DVB-T system a coherent demodulation was chosen, a channel estimation is necessary to compensate the distortions caused by the transmission channel. A two-dimensional channel estimation algorithm was used to estimate the channel. This is the same algorithm, which was used in the second dTTb demonstrator. In time direction a simple linear interpolation was used considering two adjacent pilot symbols. In the second dimension (frequency) a Wiener interpolation filter with 23 Taps was implemented.

The channel estimation algorithm provides the equaliser with an estimate of the channel transfer function. The received complex modulated values were divided by the complex channel transfer function estimation. Inside the decoder a floating soft decision was made and to get a better performance of the Viterbi decoder, additional reliability information was used. To derive such reliability information the soft decision was multiplied by the squared amplitude of the estimated channel transfer function. For almost all cases this information was uniformly quantized with ten bit, which can be regarded as floating point operation, before fed into the Viterbi decoder and the maximum quantization limit was set to a fixed value. Because of the high implementation costs in practice only three or

four bit will be used. Therefore a further degradation of about 0.5 to 1 dB can be expected.

First in Figure 2-7 and Figure 2-8, the degradation loss for the used channel estimation related to a perfect channel estimation is shown. The filter method to estimate the channel transfer function leads to a degradation loss of more than 1.6 dB. A QPSK with code-rate $r=1/2$ and guard interval= $1/4T_s$ in 2K mode was considered. All mentioned channel scattering functions were simulated and the maximum Doppler frequency ($f_{d,max}$) was 53 Hz. As far as the scattering function P=5, defined in EUREKA 147 (DAB HT I), is concerned, the maximum echo delay is larger than the guard interval, which results in large inter-carrier-interference. Therefore, the orthogonality of the carrier frequencies is destroyed and the channel estimation is not able to reconstruct the channel transfer function.

For comparison reasons, the analytical upper bound for QPSK, $r=1/2$ and perfect channel estimation is shown. One can see the close matching for P3 and also P6, which is close to the Rayleigh fading channel.

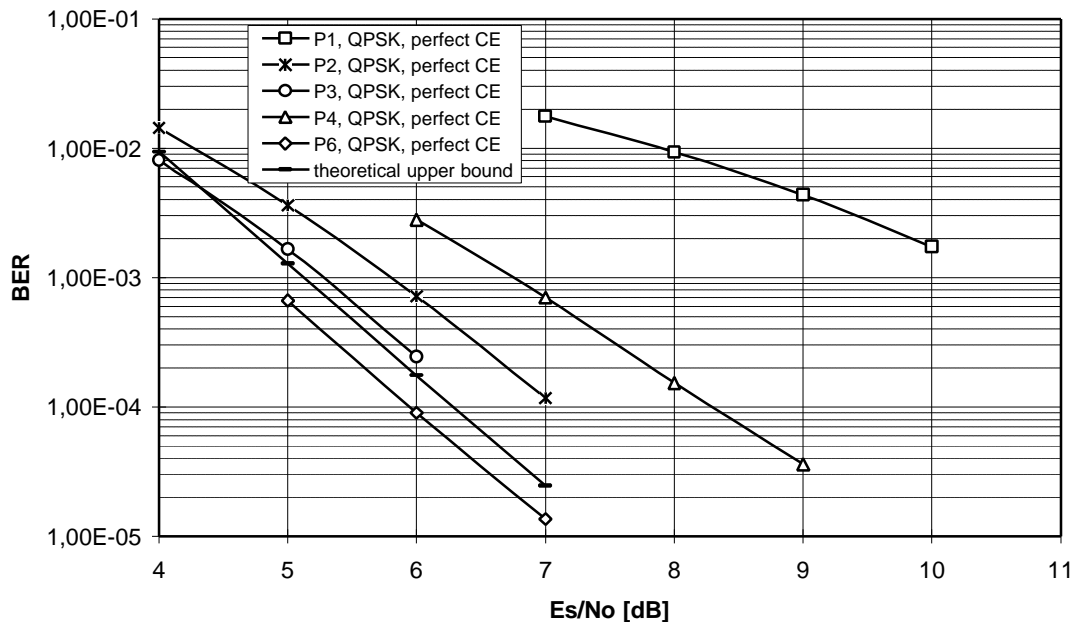

Figure 2-7: BER of DVB-T system with perfect channel estimation, 2K-mode/2, guard=1/4Ts and $f_{dmax}=53\text{Hz}$

The necessary signal energy to reach the bit-error-rate of $2e-4$ for the different scattering functions show a large variation. Only the profiles P6 and P3 reach the analytical bound. The profile P4 shows a degradation of 2 dB compared to P6 using perfect channel estimation, with real channel estimation even a 2.5 dB loss can be recognised. Especially the profile P1 seems to be a very critical reception condition for the DVB-T system in a mobile environment. A signal energy of about 6.7 dB higher compared to P6 is needed to reach the same bit-error-rate (see Figure 2-8).

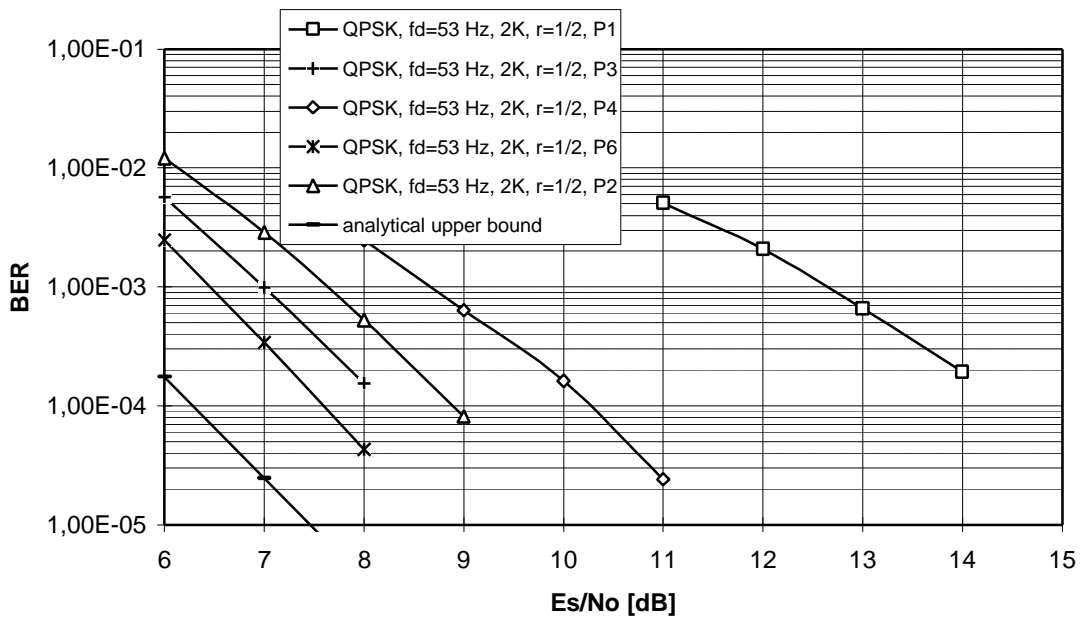

Figure 2-8: BER of DVB-T system with real channel estimation, 2K-mode, $r=1/2$, guard= $1/4T_s$

The reason for this high deviation from the theoretical result is the variation of the received signal energy. In Figure 2-9, Figure 2-10 and Figure 2-11 the received signal energy of the OFDM-symbols for the profiles P6, P4 and P1 is shown.

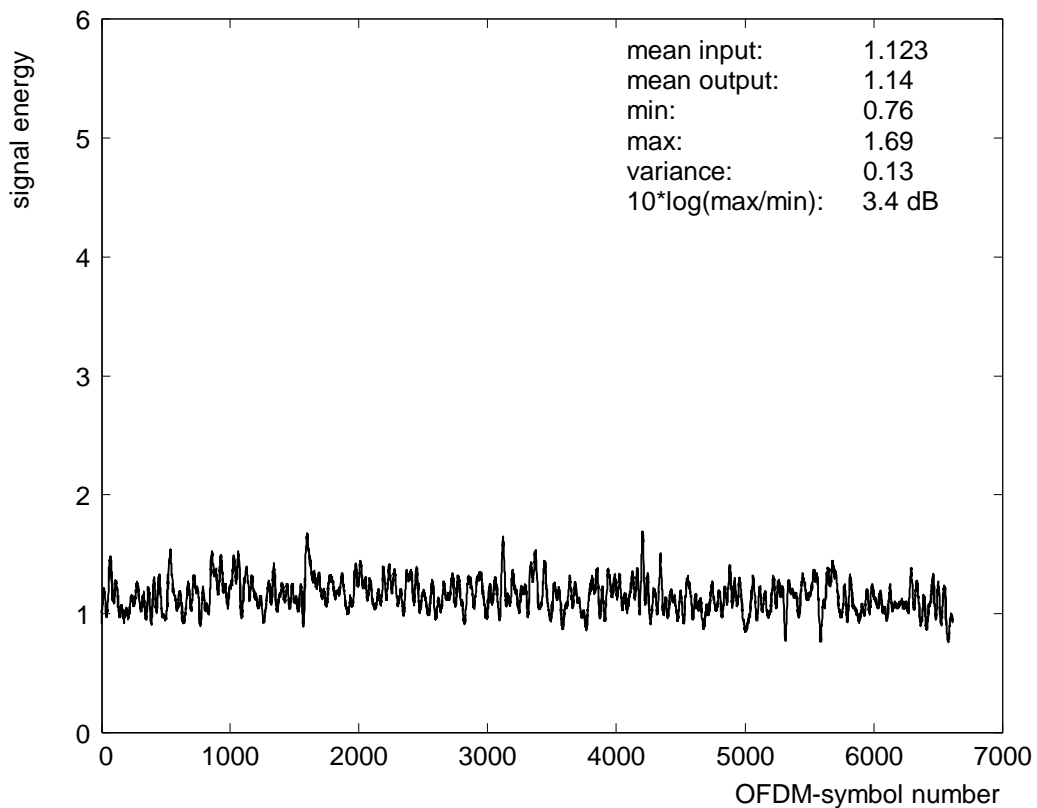

Figure 2-9: Received signal energy for profile P6

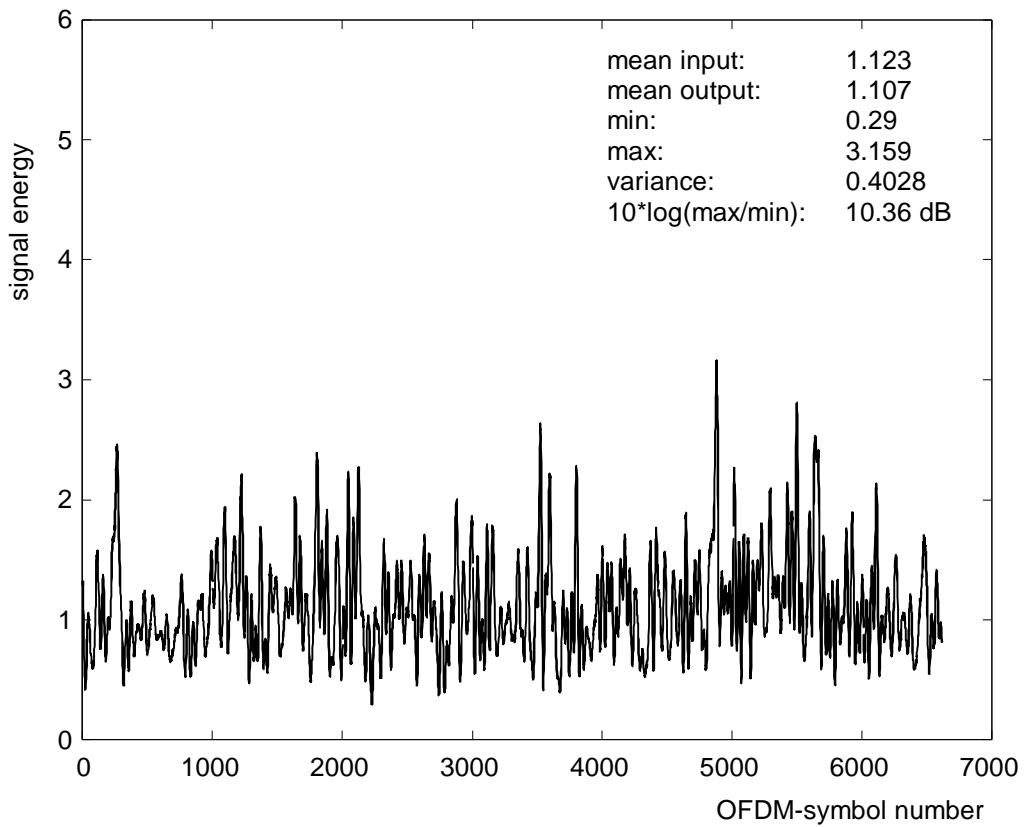

Figure 2-10: Received signal energy for profile P4

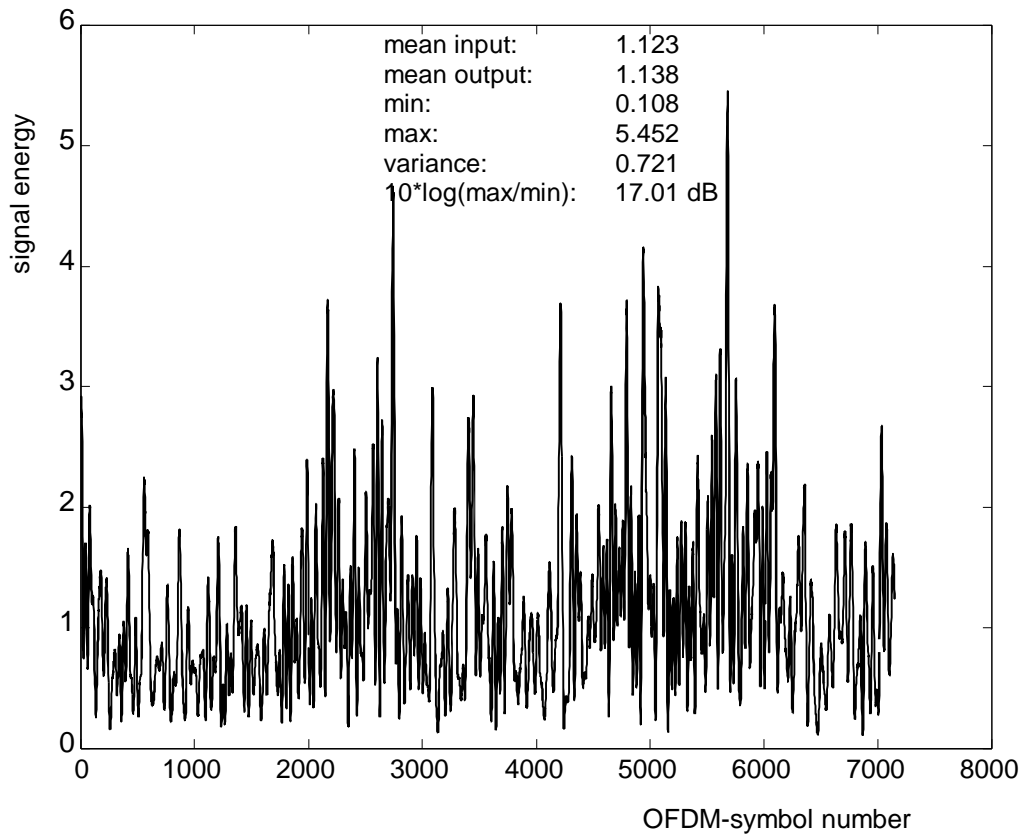

Figure 2-11: Received signal energy for profile P1

The profile P6 results in a very frequency selective channel. Therefore, the variation in time direction is small with a maximum of 3.4 dB. In such a case an ideal time and frequency interleaving can be assumed and the theoretical curve is reached. The profiles P4 and P1 show a much higher variation of the OFDM symbol energy, so that there are more symbols with a small signal-to-noise ratio resulting in high bit-error-rates. Due to the fact that the DVB-T system has no time interleaving, there is nothing to maintain an ideal interleaving and the system performance decrease. Both profiles, P1 and P4, have very short echo delays in common, which result in deep and long fades in the channel transfer function and in the high variation of 10.36 dB and 17.01 dB (see respectively Figure 2-10 and Figure 2-11).

In Figure 2-12 and Figure 2-13, the bit-error-rate for QPSK, $r=1/2$, 2K mode and guard interval = $1/4T_s$ is presented. The Doppler frequencies were chosen as mentioned above. The graphs show that the channel estimation is able to follow the time variant channel even for high velocities. Only the signal energy has to be high enough. The simulated channel type was P4 in Figure 2-12. Figure 2-13. shows a comparison between P4 and P6.

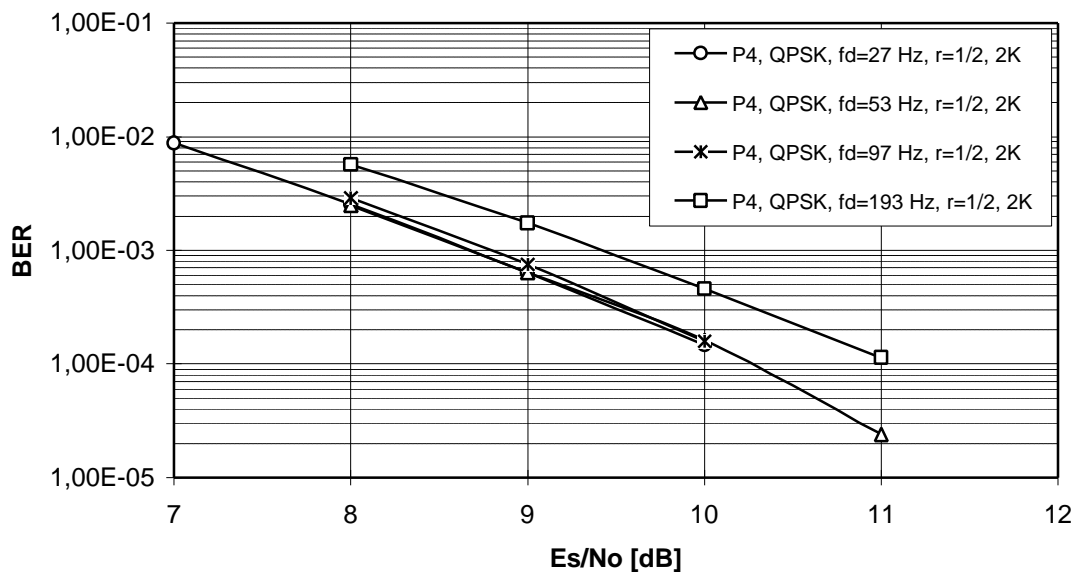

Figure 2-12: BER of DVB-T system with QPSK, $r=1/2$, P4, 2K-mode and guard= $1/4T_s$

For P4, the high Doppler frequency of 193 Hz causes a degradation loss of about 0.6 dB, whereas the lower frequencies up to 97 Hz result in nearly the same bit-error-rates. This effect shows the limit of the channel estimation which is no longer able to follow the time variant channel as good as for the lower Doppler frequencies.

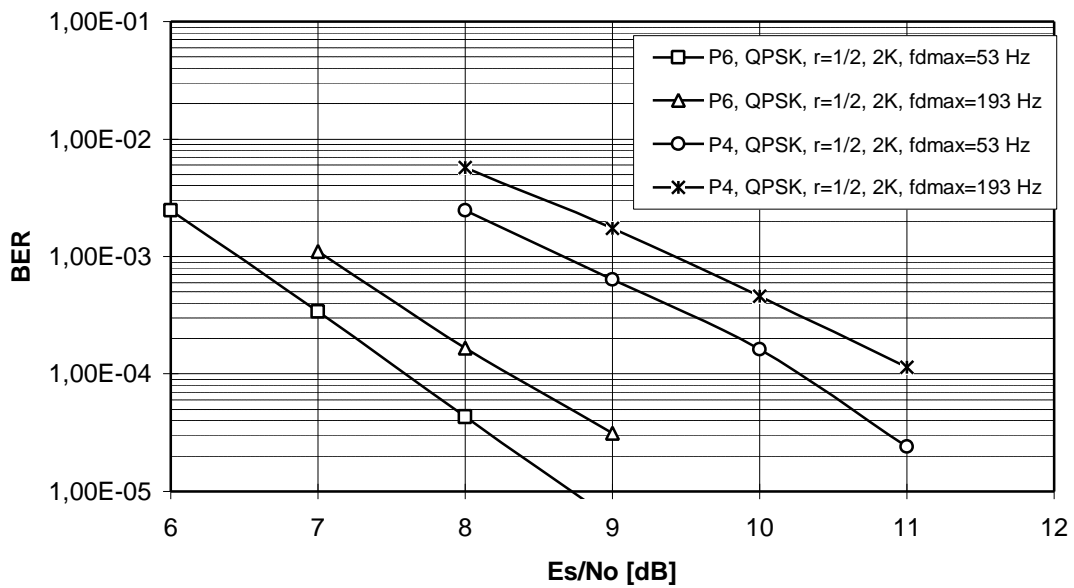

Figure 2-13: BER of DVB-T system with QPSK, $r=1/2$, P6, P4, 2K-mode and guard= $1/4T_s$

In Figure 2-14, the simulation with QPSK as modulation of the sub-carriers is shown for different code-rates ($r=1/2$ and $2/3$). For the higher code-rate $r=2/3$ and profile P4 the signal-to-noise-ratio increase about 3.1 dB to achieve a bit-error-rate of $2e-4$. Taking into account the curves of profile P6 in Figure 2-13, the loss of 3.1 dB for the higher code rate is also valid for this profile. In addition, the performance loss for the high Doppler frequency of 193 Hz increases to 2 dB with less error protection (compared to 0.6 dB with $r=1/2$).

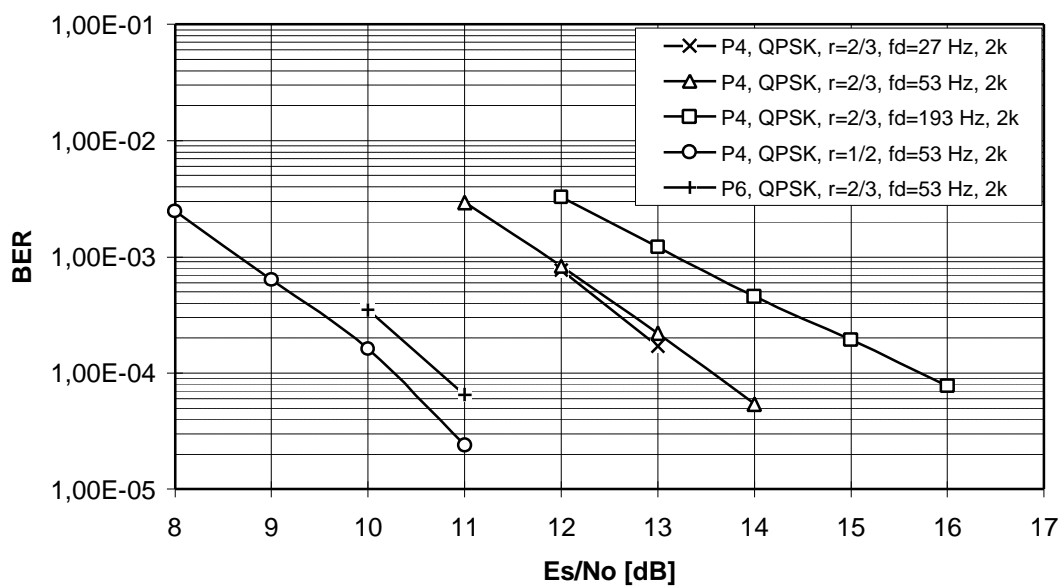

Figure 2-14: BER of the DVB-T system with QPSK, $r=1/2$ and $r=2/3$, P4, P6, 2K-mode

The following figures present the performance of the DVB-T system with a 16QAM modulation of the sub-carriers.

Figure 2-15 shows the results for different profiles (P6 and P4). In this case too, a degradation loss of approximately 2.5 dB can be realised between these two reception channels (see also Figure 2-13). The simulations were made with the lower code rate of $r=1/2$.

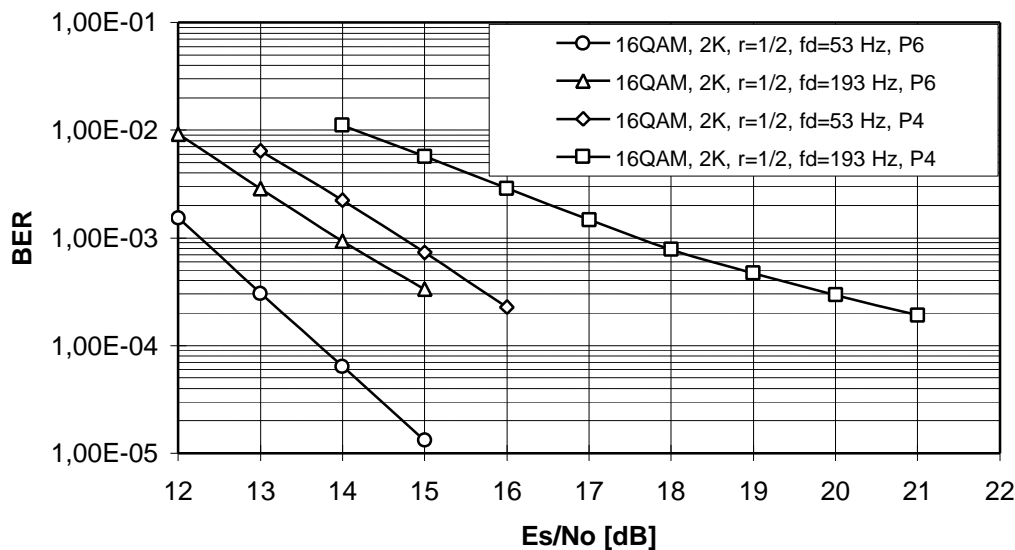

Figure 2-15: BER of the DVB-T system with 16QAM, $r=1/2$ and $r=2/3$, P4, guard=1/4Ts and 2K mode

In Figure 2-16 the results for different Doppler frequencies are presented. In this simulation, the code rate was $2/3$, the guard interval was $1/4T_s$ and the 2K mode was used. The scattering function, which was simulated, was P4.

For this protection ratio the channel estimation is only able to follow the time variant channel for low Doppler frequencies. For 193 Hz Doppler frequency the graph asymptotically approaches a high remaining bit-error-rate. In such a case no reception operation is possible at all.

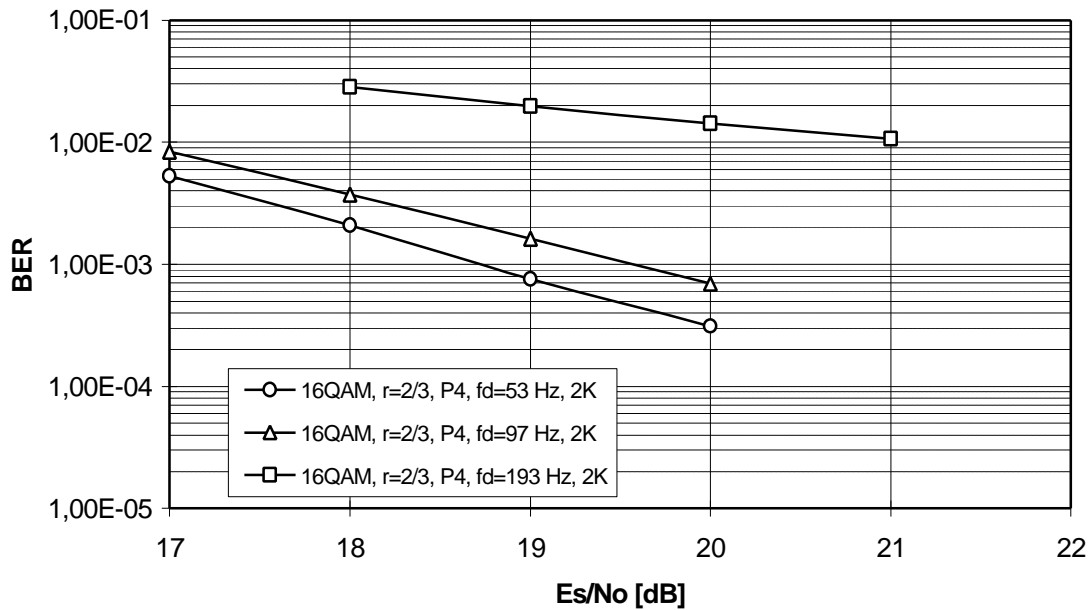

Figure 2-16: BER of DVB-T system with 16QAM, $r=2/3$, channel=P4, 2K-mode and guard= $1/4T_s$

For the 16QAM as modulation of the sub-carriers the degradation loss of code-rate $r=2/3$ compared to $r=1/2$ is about 4 dB for a bit-error-rate of $1e-3$ and approximately 4.5 dB for a BER of $2e-4$. So with the higher error protection ($r=1/2$) the DVB-T system can cope with high Doppler frequencies even for 16QAM modulation of the sub-carriers. Nevertheless, in case of critical reception conditions (P4) the bit-error-rate for the Doppler frequency of 193 Hz flattens out, but the curve reaches the necessary limit of $2e-4$, although the loss compared to a Doppler frequency of 53 Hz amounts to 5 dB.

In principle the working Doppler frequencies have to be divided by four for the 8K-mode. Figure 2-17 and Figure 2-18 present simulation results for the QPSK and 16QAM with code rate $r=1/2$ and scattering function P4 in comparison to the 2K-mode.

For the QPSK as modulation of the sub-carriers the channel estimation works for a Doppler frequency of 27Hz and 53 Hz, but the BER will flatten out for a frequency of 97 Hz. In addition, the bit-error-rate for the 2K-mode with a Doppler frequency of 193 Hz is nearly the same as for the Doppler frequency of 53 Hz in the 8K-mode.

For the 16QAM, a Doppler frequency of 40 Hz shows a performance loss of 1.6 dB compared with the curve of 27 Hz. The curve of 53 Hz Doppler frequency approaches a remaining bit-error-rate, which is low enough for a good picture quality, but results in a degradation of approximately 6 dB in case of a bit-error-rate of $4e-4$.

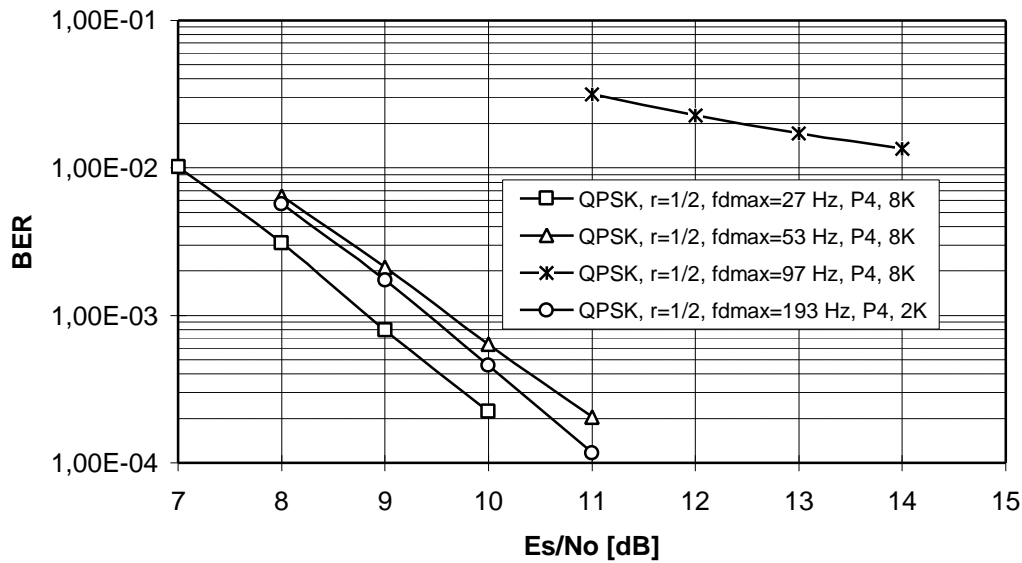

Figure 2-17: BER of DVB-T system with QPSK, $r=1/2$, channel=P4, 8K- and 2K-mode and guard=1/4Ts

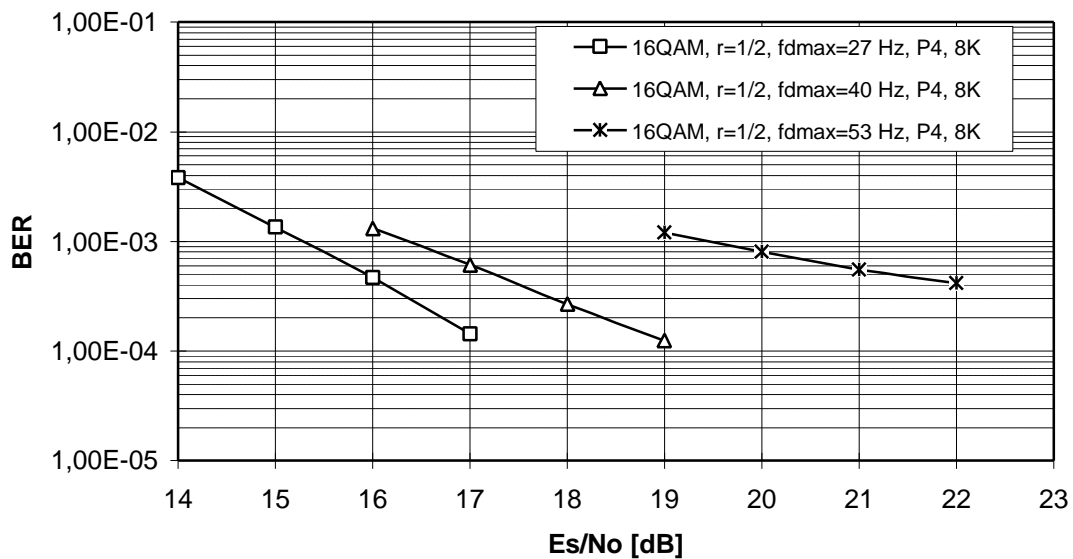

Figure 2-18: BER of DVB-T system with 16QAM, $r=1/2$, channel=P4, 8K-mode and guard=1/4Ts

All of the mentioned investigations never include any simulations of time invariant channel transfer functions, i.e., Doppler frequency $f_{d,max.} = 0$ Hz, where in this case, the simulated channel would be a “one shot” example. Therefore it would be a random selection, if an advantageous or a bad channel transfer function is simulated. In addition, for investigations of mobile reception it is not meaningful to consider such a case, because depending on the chosen channel a reception is possible or not. This has to be taken into consideration for network planning. In the case of stationary reception the

gain and directivity pattern of the antenna can often be used to solve this problem. Concerning the mobile reception it is interesting how long bad reception conditions last. Further investigations, especially including field trials, have to be made to get a clear impression of this problem and the necessary transmitted power to overcome the problem of signal blocking.

2.3 Laboratory Measurements

Deutsche Telekom Berkom carried out extensive measurement series to investigate the performance of the DVB-T specifications in a mobile environment with a DVB-T compliant modem. The laboratory tests were done corresponding to the procedures from the task force laboratory tests (TFLT) of the VALIDATE project. For all measurements a 2K-FFT signal was used. The transmission frequency was 650 MHz (channel 43). All modulations schemes with code rate 1/2 were used with two different guard intervals.

To simulate a mobile environment a hardware channel simulator was used. This device is able to generate several signal paths with varying delay and with a maximum Doppler frequency of $f_D=121$ Hz. This Doppler frequency is equivalent to a speed of 202 km/h in the channel 43.

As a reference for the reception quality two kinds of failure points have been considered. For the first one the bit error rate (BER) before Viterbi decoding has to be measured. The failure point BER depends on the used code rate. The BER values for code rate 1/2 is $8 \cdot 10^{-2}$ in the AWGN channel case and approximately $9 \cdot 10^{-2}$ in the Rayleigh channel. These points correspond to a BER of $2 \cdot 10^{-4}$ after the Viterbi-Decoder. This method is called the "objective" failure point method. It has to be mentioned that the channel errors before the Viterbi decoder in mobile reception conditions i.e. high Doppler frequencies are highly correlated. The second kind of failure point is determined by the subjective assessment of picture quality. A sufficient picture quality is achieved if no errors are visible in a picture sequence of 20 seconds. This method is called the "subjective" failure point method.

Figure 2.18 illustrates the performance difference between "objective" and "subjective" measurements for the most vulnerable constellation, i.e. 64-QAM. In this figure the noise margin loss versus Doppler frequency (code rate 1/2, guard interval 1/4) has been considered in the case of a single 0 dB echo of $\tau=25\mu\text{s}$ for the "objective" and the "subjective" measurement methods. The difference is about 4 dB between "subjective" and "objective" for lower Dopplers and increases up to 15 dB for high Dopplers up to 85 Hz. We don't have the same difference over the whole area of measurement. Furthermore the measurements are only possible up to 85 Hz with the "objective" method. Consequently the "objective" failure point is only partially

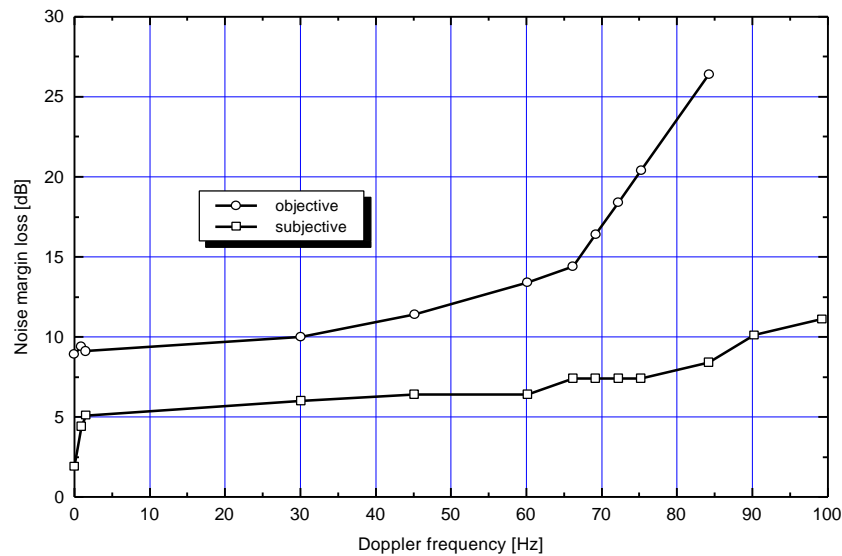

Figure 2.18: Comparison of “subjective”/“objective” measurements methods (64-QAM, r= 1/2)

suitable for mobile measurements, since the required BER of $2 \cdot 10^{-4}$ sometimes can not be reached, although the “subjective” method shows no system failure. However, the “subjective” failure point provides the reception limit, which corresponds to a higher BER of approx. $1 \cdot 10^{-3}$ after the Viterbi decoder. This has to be kept in mind, when comparing SNR figures, where large differences can occur when comparing subjective and objective results. Therefore, in the following the “subjective” failure point method will be used for all measurements.

The two paths model with Doppler shift was used for the laboratory measurements. The main path is disturbed by the delayed echo path which is influenced by Doppler effects and attenuation. The critical case of 0 dB echo in all measurements has been taken into account. The step size of the power attenuator was one dB. The noise margin loss represents the performance loss with respect to the AWGN channel case, where in AWGN, the C/N values for QPSK, 16-QAM and 64-QAM modulation schemes have been measured, which are 5.4 dB, 12.1 dB and 18.9 dB, respectively.

Figures 2.19 to 2.21 show the noise margin loss of QPSK, 16-QAM and 64-QAM for a 0 dB echo with different Doppler frequencies with a guard interval length of $T_g = T_s/4 = 56 \mu s$ (code rate 1/2). The well known cliff edge effect can be seen at a guard interval length of $1/4$. This is due to the interpolation and filtering in the channel estimation process. Echoes outside the guard interval are not equalised and are to be considered as pure interference, producing a rapid performance degradation. The degradation increases with higher Doppler frequencies and higher modulation order: in fact, before the maximum delay of 56 μs is reached, the system performance degrades rapidly at 52 μs (QPSK), 47 μs (16-QAM) and 40 μs (64-QAM).

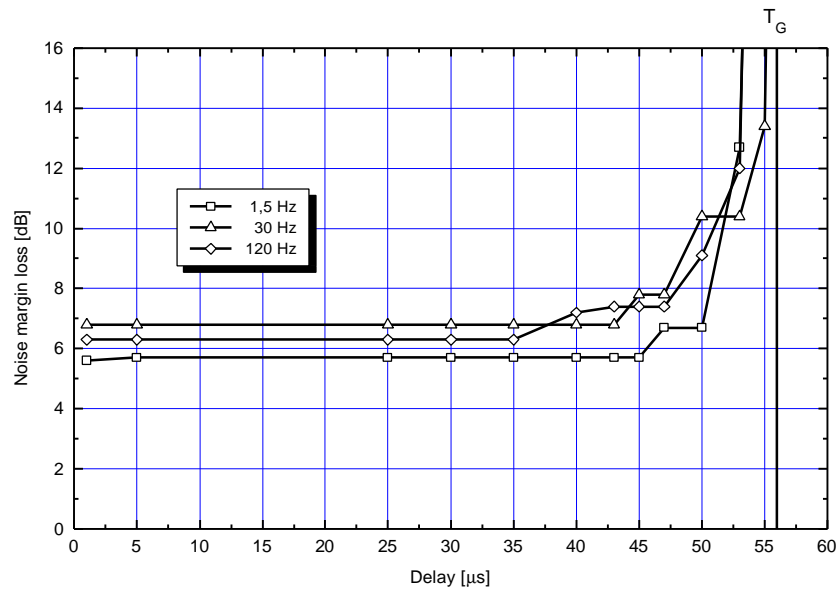

Figure 2.19: Noise margin loss of QPSK in the presence of a 0 dB single echo ($T_g=T_s/4$)

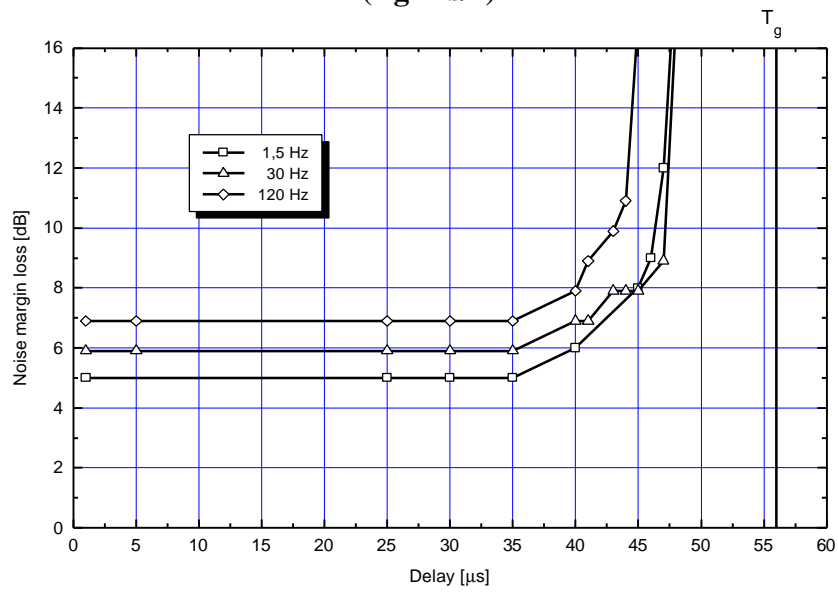

Figure 2.20: Noise margin loss of 16-QAM in the presence of a 0 dB echo ($T_g=T_s/4$)

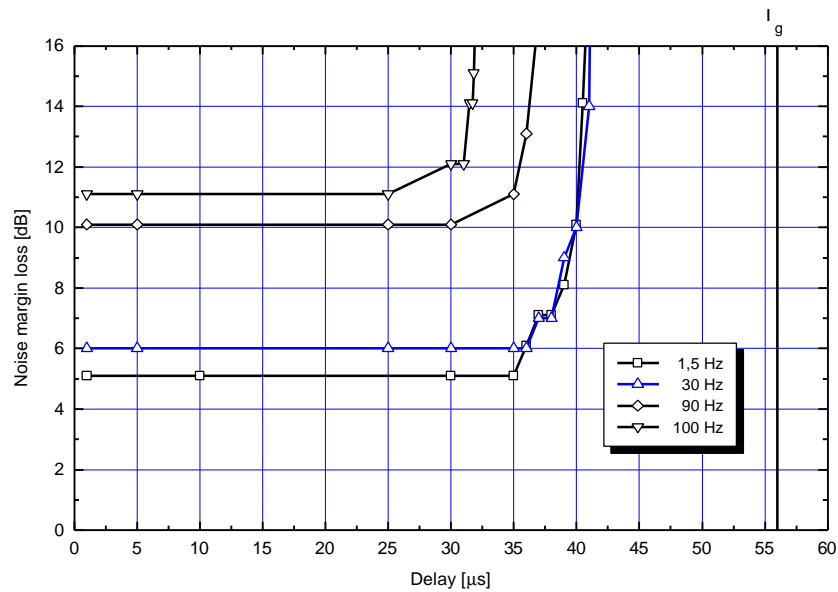

Figure 2.21: Noise margin loss of 64-QAM in the presence of a 0 dB echo ($T_g=Ts/4$)

Measurements performed with a guard interval of $T_s/8$ showed that the problem of rapid performance degradation does not happen within the guard interval. The measurements show a relative constant performance degradation dependent on the Doppler frequencies within the guard interval (see Figure 2.22 for QPSK).

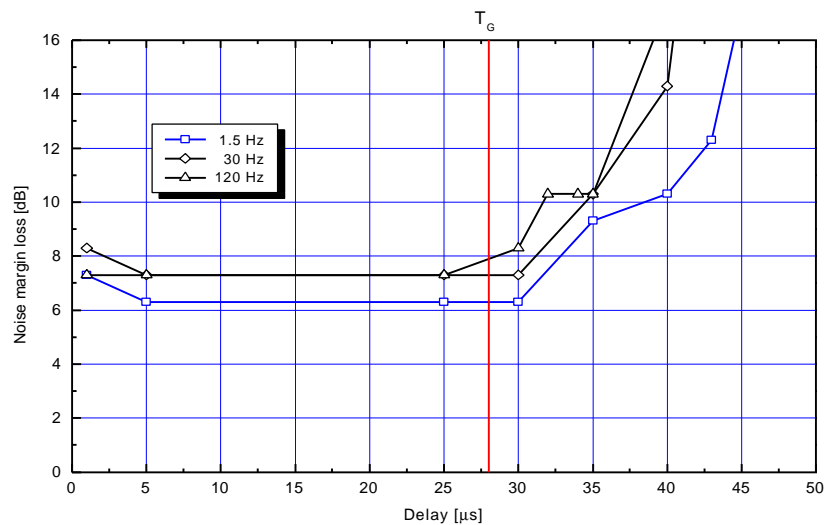

Figure 2.22: Noise margin loss of QPSK in the presence of a 0 dB echo ($T_g=Ts/8$)

Figure 2.23 shows the noise margin loss for different DVB-T modulations schemes versus speed at a echo delay of 25 μs . At a speed of 200 km/h , the QPSK and the 16-QAM need about 6-7 dB more C/N with respect to the AWGN channel case, i.e. approx. 11.4-12.4 dB (QPSK) and 18.9-19.1 dB (16-QAM).

The need of additional C/N is about 11 dB higher for 64-QAM (i.e. $C/N=29.9$ dB) at a speed of 160 km/h. The 64-QAM needs for a speed of 100 km/h about 8 dB C/N more (i.e. $C/N = 26.9$ dB) than for the AWGN channel case. Consequently, using the explained subjective criterion, it is possible to transmit a data rate of 15 Mbit/s with a 64-QAM up to a speed of 100 km/h at C/N of about 27 dB.

It should be noted that the strong degradations of about 5 dB at a speed of few km/h are caused by a temporal filter on the channel state estimation of the receiver. This provides a good PAL CCI performance. The effect is not fundamental to DVB-T. An optimised receiver for mobile reception should show a better performance in this point.

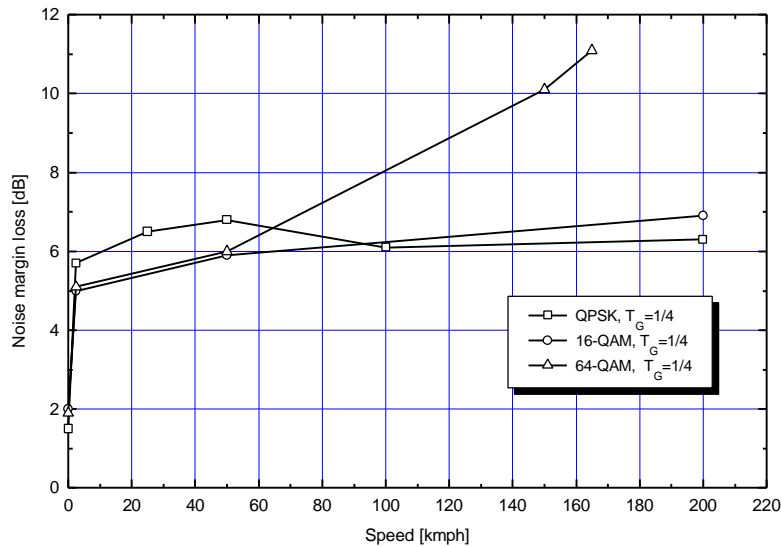

Figure 2.23: Noise margin loss of DVB-T modes versus speed (64-QAM, rate 1/2)

2.4 Synchronisation Issues

Synchronisation in terrestrial transmission, using the DVB-T standard, is based on a number of reference signals transmitted in every frame and on the signal repetition in the guard interval. The conditions are characterised and roughly analysed as shown in the Table 2.2:

Synchronisation	Signal conditions	... available	Start procedure	Continuous synchronisation
Time, coarse	Signal repetition in the guard interval;	once per symbol	Correlation, setting the symbol timing	[Cont. control to be able to react on fast changes (optional)]
Time, fine	scattered pilots	once per symbol (but reduced # of carriers)		Pulse response evaluation; contin. correction of symbol timing
Frequency, coarse	Continual pilots	Continuously (every symbol but reduced # of carriers)	Correlation with carrier scheme (over f); choice of rough position;	

			estimate of Δ with error $< 1/2$ carrier-spacing; frequency correction	
Frequency, fine	Continual pilots (+ scattered pilots)	continuously (every symbol but reduced # of carriers)		Phase deviation per symbol; contin. freq. + common-phase error correction
Frame	TPS information	once per frame	TPS evaluation over up to one frame	Cont. TPS evaluation

Table 2.2: The synchronisation techniques for a DVB-T receiver

Supposing an adequate processing in the receiver (complexity), the following performance can be achieved with terrestrial DVB-T signals:

- Symbol timing and frequency deviation correction are achieved within the time of at least two symbols (560 us, for 2 K), or under bad noise conditions within these two symbols plus a few symbols for averaging processes.
- Both timing and frequency correction can be maintained (updated) with symbol rate, which allows a proper function even under the constraint of high Doppler frequencies. At 2K mode more than 500 Hz should be possible, equivalent to a speed of more than 500 km/h at 800 MHz.
- Frame synchronisation and assignment of received data are achieved within ≈ 1.5 frames (28.6 ms, 2K, $T_g=1/4$),
- With adequate methods, framing and to a certain extend also a sufficient frequency deviation correction can be maintained over signal gaps of 10 ... 100 frames (depending on the performance of the reference oscillator systems); the symbol timing itself and, if necessary, an update of the frequency deviation correction is achieved within a few symbols (as explained above).
- If - due to longer signal interruption - a resync will be needed, the additional time to achieve this is negligible compared with the interruption itself.
- Compared to the re-sync time of the MPEG decoder (about 0.5 s), the synchronization time of the front-end (time, frequency, frame) is very short.

To summarise, with DVB-T and with respect to synchronisation, no special drawbacks are expected under mobile-reception conditions. An adequate technique in the receiver will be needed, which should be feasible at reasonable cost by future large-scale integration.

2.5 Results of Field Trials

Deutsche Telekom and Deutsche Telekom Berkorn made field trial measurements to study the performance of a DVB-T receiver in real mobile environments. The field trial was carried out in the area of Cologne.

The trials were focused on QPSK transmission. However, for 16-QAM and 64-QAM modes, first tests were carried out. The following conditions were considered during the measurements:

Transmitter side:

- 1 KW ERP in UHF-Channel 40 (626 MHz), horizontal polarisation,
- DVB-T Parameter:
 - QPSK, code rate $r=1/2$, (16-QAM, 64-QAM code rate $r=1/2$)
 - 2k-FFT, guard interval $T_s/4$,
 - Net-bit-rate 4.98 Mbit/s for QPSK
- One live coded and multiplexed 4 Mbit/s - MPEG-II TV-Signals.

Receiver side:

- DVB-T “consumer like” receiver with a noise figure of app. 8.5 dB. The AWGN- and mobile performance were measured by laboratory tests before. Table 2.3 should give a first practical orientation. It shows which C/N’s are expected approximately for different constellation orders. The main results were presented in Section 2.3 (Laboratory Measurements).
- Receiver antenna: slot antenna with an approximately circular diagram on the top of the car (5 dB gain).
- Measurement receiver: ESVB 12 with 8 MHz bandwidth and power sampling rate of 1 kHz.
- Measurement car: “Opel Omega” (Antenna height app. 2m)

	QPSK	16-QAM	64-QAM
AWGN - Threshold	16 dB μ V	22 dB μ V	30 dB μ V
Mobile- Threshold 1	22 dB μ V	29 dB μ V	38 dB μ V

Table 2.3: AWGN and Mobile Thresholds

2.5.1 Itineraries and Measurements:

¹ 0dB Echo with a speed of 100 km/h in channel 40

Three different routes were chosen for the measurements (see Figure 6.1). Route 1 was the Cologne motorway with a distance of 10 km. Here, the transmitter was behind the car for the second part of the route. The highest speed was app. 100 km/h. There is a special handicap on this route. After 4.5 km the car passes through a tunnel of about 400 m long that leads to a power attenuation of app. 40 dB. Routes 2 and 3 are more typical for the city with a maximum speed up to 50 km/h.

Two parameters were stored simultaneously during the test tours. The first one was the received input power and the other one was a subjective parameter for the video quality condition (go, no-go). The sampling rate for these parameters was 1 kHz. Figure 2.25 describes the used set-up in the measurement car.

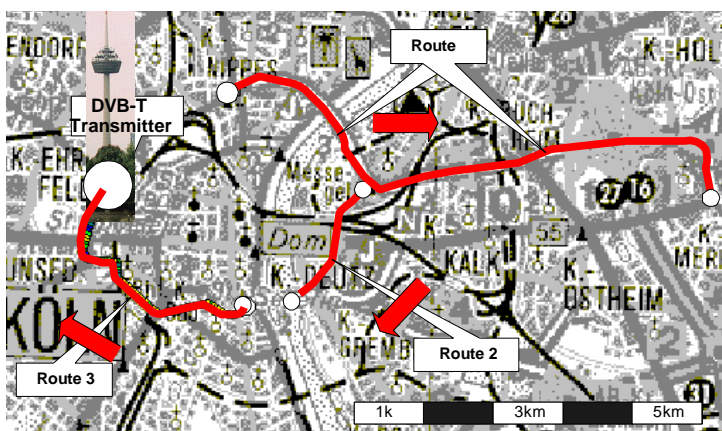

Figure 2.24: Map of Cologne with tested Routes

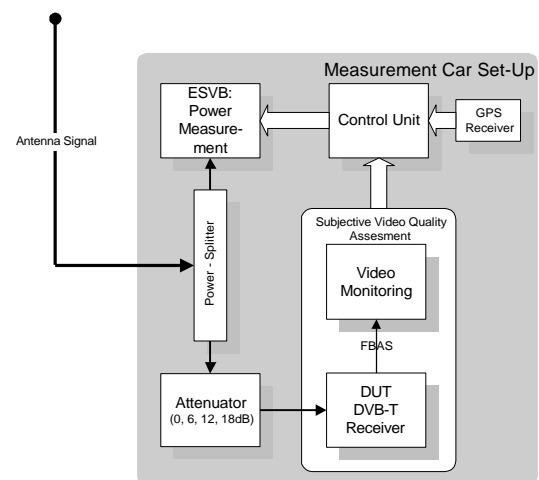

Figure 2.25: Measurement Set-Up

The measurements were performed several times by varying an additional power attenuation (0 dB, 6 dB, 12 dB, 18 dB) of the received DVB-T Signal for each route.

In Annex I a survey of the measurements on route 2 with QPSK have been presented, where the “grey-zone” presents the presence of errors in the received video sequence. Annex II presents a comparison of performance of different constellations diagrams on routes 1 and 3. In both annexes, in each figure a set of the following 2 diagrams have been presented:

- The diagram “Level [dB μ V/8 MHz] versus Distance [km]” shows the measured level along the route depending on the Position. A second (+infinite) plot indicates in the same diagram whether the received video was without errors or the video quality was poor or down. Hence, it is possible to identify the state of the DVB-T reception versus distance and level. Two horizontal lines mark the thresholds identified by the laboratory tests (see Table 2.3). The Video Error Rate is indicated -for the current plot- in the lower left (duration of faulty reception with whole measurement time).
- The diagram “Speed versus Distance” gives the values of the speed along the routes.

2.5.2 Evaluation of Measurements

Especially for frequency planning it would be interesting to know the required received signal strength with a certain probability to guarantee a Video Error Rate of less than 1%. For these reasons power distributions and the Video Error Rates of the tested routes were computed during the measurements. Due to the tests with different attenuation at the same route the corresponding power distributions will be shifted to lower values. Therefore, the Video Error Rates will be increased step by step.

Figure 2.26 shows that the lowest Video Error Rate was 2% (corresponding to 21 dB μ V) for QPSK with 0 dB attenuation for the first route. This means that in case 2% of levels are not lower than 21 dB μ V, then we get a coverage probability of 98 % for this route. Tests with more attenuation produced more errors in this route.

Figure 2.27 gives similar results for route 2. The first test was error free with 0 dB attenuation. The next attenuation step leads to a Video Error Rate of 0.4 % and the corresponding level was 21 dB μ V. It can be estimated, that a coverage probability of 99% can be reached for this route if 99% of levels are not lower than 22 dB μ V. This level corresponds to the laboratory mobile threshold given in Table 2.3 and is higher as for route 1. Results of route 3 (Figure 2.28) are quite similar.

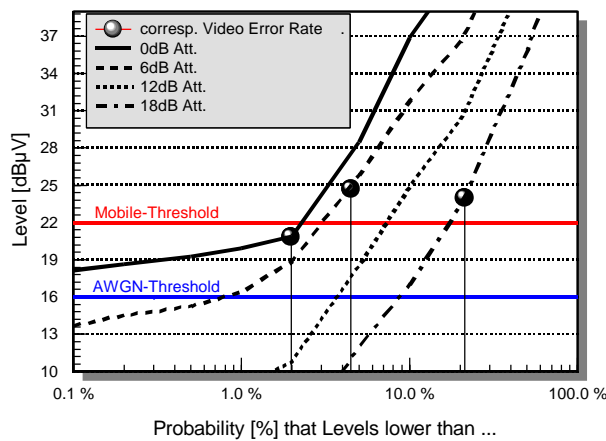

Figure 2.26: Route 1, QPSK

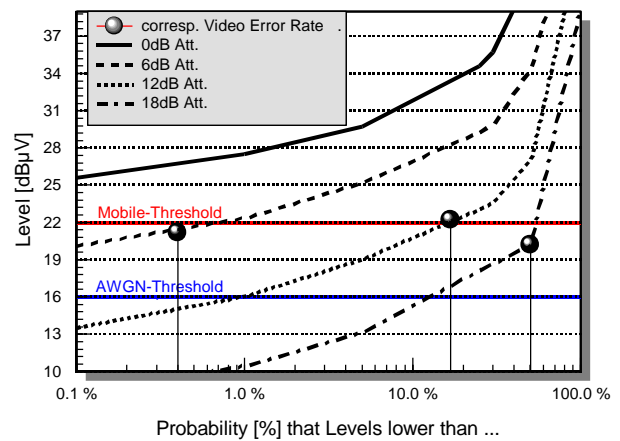

Figure 2.27: QPSK on Route 2

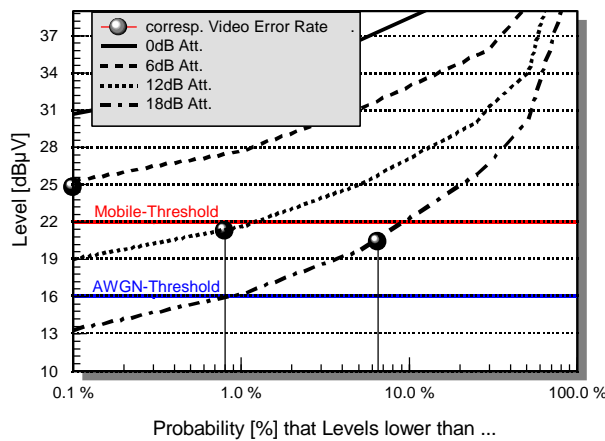

Figure 2.28: QPSK on Route 3

A strength level higher than 22 dB μ V for 99% of time gives a coverage guarantee of 99% for route 3. (To reach a 99.9 % coverage the level should not be lower than 25 dB μ V for 99.9 % of time.)

The analysis of these 12 tests in Figures 2.26-2.28 has shown, that the level of 22 dB μ V describes very well the mobile threshold. The intersection of this threshold line and current power distribution function can safely predict the Video Error rate.

2.5.3 16-QAM and 64-QAM Tests

Additional measurements were done for 16-QAM and 64-QAM transmission at the same routes. However additional tests with different attenuation were not carried out. Figures 2.29 and 2.310shows the analysis results for these tests.

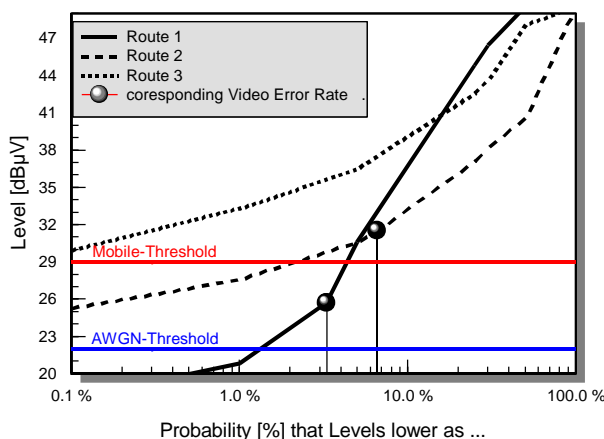

Figure 2.29: 16-QAM on different Routes

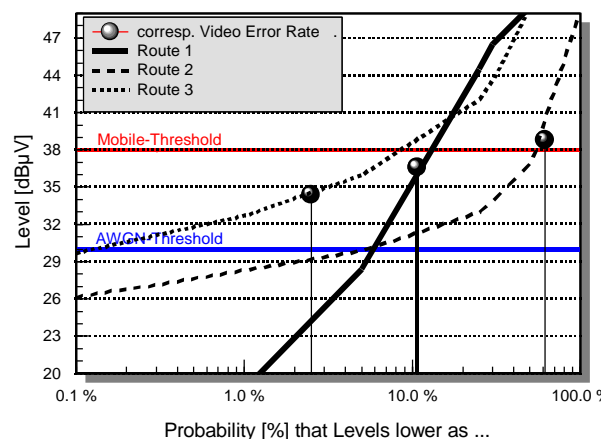

Figure 2.30: 64-QAM on different Routes

The analysis of Figure 2.29 for 16-QAM shows that the same statement as in the case of QPSK tests is not possible, where there is a contradiction between route 3 (error free)

and route 2. Route 3 works with levels lower than 30 dB μ V, but route 2 has a Video Error Rate of 6.6 % with higher level of 31.5 dB μ V.

A prediction based on a mobile threshold of 29 dB μ V for 16-QAM would lead to Video Error Rate of 4 % for Route 1 (measured 3.3 %), 1 % for Route 2 (measured 6.6 % !) and <0.1% for Route 3 (no Video Errors were detected). That means further tests are necessary.

The 64-QAM test (Figure 2.30) did not have such contradictions as the 16-QAM test. The predicted error rate for route 1 would be about 4 times higher using the mobile threshold. A worst case mobile threshold of 36 dB μ V (neglecting the 38 dB μ V of route 2) is more realistic. The test on route 2 has a very high Video Error Rate of about 60 % because of not sufficient input power.

In general for the 64-QAM test the Video Error Rate is limited by the real power distributions along the tested routes only. A worst case mobile threshold of 36 dB μ V was identified.

It has to be noticed that field tests have fully confirmed results from laboratory tests and simulations of the DVB-T modes with code rates of 1/2. The thresholds (for 99% of time) assumed for the examined receiver (corresponding to the pertinent constellation order) corresponds to a coverage guarantee for video transmission for 99% of time. Mobile reception requires additional power at receiver input compared to the AWGN- and portable channel. A margin of 6 - 8 dB seems to be sufficient for mobile reception (at least for the field tests set-up and terrain) in relation to the AWGN- channel.

The analysis of the recorded data of the field tests has proven short re-synchronization times after transmission interruptions. Additional simple laboratory tests have shown that the necessary time for the re-synchronization of the DVB-T receiver (without MPEG decoding) is much shorter than the required time for the re-synchronization of the MPEG decoding process.

Keeping in mind that the used receiver was not optimised for mobile reception, better results can be expected in the future.

3 Performance of Digital Multimedia Broadcasting (DMB)

The EUREKA DAB system (ETS 300 401) [2] is also well suited to transport MPEG-coded video in a stream mode sub-channel for mobile reception. A draft of the proposed DMB (Digital Multimedia Broadcasting) system can be seen in Figure 3.1 [6].

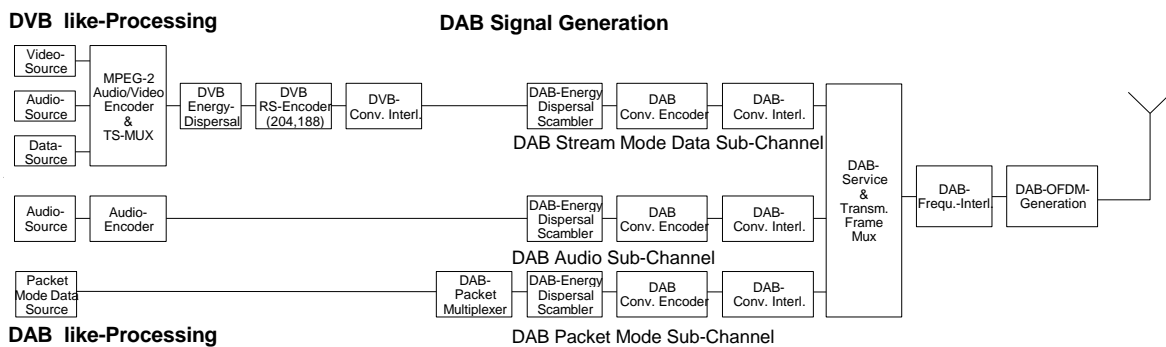

Figure 3.1: System proposal for DMB

MPEG-coded video (Transport Stream, TS) is carried in a DAB stream mode sub-channel. Depending on the data-rate, one can transmit DAB-Audio and Packet-Mode Data additionally. Figure 3.1 shows the main blocks (that are already defined in standards [1],[2]) for the system. The DVB-like processing-block up to the interleaved video data (in order to be compatible with the DVB-T standard and to be able to use existing ICs), a normal DAB source processing and the DAB signal generation unit.

3.1 Outer Coding

Since MPEG-coded video data is very sensitive to channel errors, one should guarantee a bit-error rate of less than 10^{-6} to 10^{-8} . Thus, depending on the receiving conditions, one should perform an outer coding in addition to the inner convolutional coding of DAB. To reduce complexity, one uses as many commonalities as possible with the DVB standard, i.e., DVB MPEG 2 source coding, DVB energy dispersal, DVB outer RS (204,188) code and the DVB convolutional interleaver.

The DAB/DMB Stream Mode will be used for transmission of the scrambled (DVB energy dispersal), Reed-Solomon (204,188) coded and convolutionally (DVB) interleaved MPEG-2 Transport Stream (TS). Therefore, the energy dispersal is compatible to DVB-T [1].

MPEG 2-TS packets of length 188 bytes are encoded using the outer systematic Reed-Solomon shortened Code, RS(204,188, t=8). The codewords (coded TS-packets) is then convolutionally interleaved, using the convolutional interleaver specified in DVB-T [1].

3.2 Synchronisation of MPEG TS-packets with Common Interleaved Frames

In order to exploit the capacity (available data-rate) as much as possible, no synchronisation of TS-packets (204 byte) and CIFs will be performed. So, no padding bits have to be inserted, in order to have an integer number of RS-coded TS-packets (of length 204*8 bits) within one Common Interleaved Frame (CIF) (maximum capacity is 55296 bit/24ms). I.e., it is allowed, that one RS-coded TS-packet is split and distributed among two consecutive CIFs.

3.3 Inner Convolutional Coding

The RS-coded TS-packets have to be mapped onto the DAB sub-channel. In stream-mode, DAB provides data-rates in multiples of 8 kbit/s or 32 kbit/s, depending on the equal error protection used. Without the restriction of allowing only an integer number of RS-coded TS-packets within one CIF, the following maximum data-rates can be provided by DMB. Table 3.1 shows the available inner code-rates (convolutional coding using equal error protection, EEP), the associated number of TS-packets/CIF, and the maximum net video and audio data rate.

Maximum net video+audio (TS) data rate (before RS) [kbit/s] TS=188Byte	Data-rate after RS (204,188) encoding [bit/s] (TS: 204 Byte)	Number of TS-packets/ CIF	Max. data-rate before conv. Coding (n * 8 kbit/s or m * 32 kbit/s)	Conv. code-rate (Protection Profile P)	Gross data-rate [kbit/s] (CUs/CIF)	Overall code-rate (RS + Conv. Code)
530.8	576.000 (352.94 TS/s)	8.47	576k (72 * 8k) 216*64 bit/CIF	1/4 (1A) n * 8kbit/s	2304 (864)	0.23
796.2	864.000 (529.41 TS/s)	12.71	864k(108 * 8k) 324*64 bit/CIF	3/8 (2A) n * 8kbit/s	2304 (864)	0.34
943.7	1024.000 (627.45 TS/s)	15.06	1024k (32 * 32k) 384*64 bit/CIF	4/9 (1B) m*32kbit/s	2304 (864)	0.40
1061.6	1152.000 (705.88 TS/s)	16.94	1152k (144 * 8k) 432*64 bit/CIF	1/2 (3A) n * 8kbit/s	2304 (864)	0.45
1209.1	1312.000 (803.92 TS/s)	19.29	1312k (41 * 32k) 492*64 bit/CIF	4/7 (2B) m*32kbit/s	2296 (861)	0.52
1415.5	1536.000 (941.18 TS/s)	22.59	1536k (48 * 32k) 576*64 bit/CIF	2/3 (3B) m*32kbit/s	2304 (864)	0.60
1592.5	1728.000 (1058.82 TS/s)	25.41	1728k (216 * 8k) 648*64 bit/CIF	3/4 (4A) n * 8kbit/s	2304 (864)	0.68
1680.9	1824.000 (1117.65 TS/s)	26.82	1824k (57 * 32k) 684*64 bit/CIF	4/5 (4B) m*32kbit/s	2280 (855)	0.72

Table 3.1: Code-rates and associated data rates in case of an outer RS-Code.

3.4 Simulation results

DMB, as well as DAB, is designed for mobile reception either in a single frequency network (SFN) or in multi frequency network (MFN). Table 3.2 shows some parameters of the different transmission modes:

Parameters	Mode I	Mode IV	Mode II	Mode III
Number of carriers	1536	768	384	192
Frame duration	96 ms	48 ms	24 ms	24ms
Symbol duration	1246 μ s	623 μ s	312 μ s	156 μ s
Guard interval, Tg	246 μ s	123 μ s	62 μ s	31 μ s
Distance between Tx	90 km	45 km	22.5 km	11.25 km
Frequency band	Band III		L-Band	
Applications	large SFN	medium SFN	small SFN	satellite DMB

Table 3.2: Parameters of the DAB/DMB system for different modes.

The system parameters were designed to enable a mobile reception at speed of up to 250 km/h (provided the corresponding frequency band is used). Furthermore, DAB/DMB tolerates a maximum echo delay of up to 1.2 Tg [6].

When transmitting video, a bit-error-rate less than 10^{-3} before the RS-decoder seems tolerable, which corresponds to a bit-error-rate after the RS-decoder of less than 10^{-6} . Assuming a burst error (with approx. 60 errors) during an error event, this results in approx. only one error event during 60 seconds of video at a bit-rate of 1 Mbit/s. Furthermore, this error-event can either cause a severe failure or might not even be noticeable. Therefore, the recognisable error events occur even less than once per minute. The assumption of a minimum bit-error-rate of 10^{-3} seems even more realistic, since intelligent error concealment strategies may further reduce the effects of transmission errors.

Out of the possible convolutional code-rates (see Table 3.1), the following code-rates seem reasonable both in resulting data-rate and performance: Profile 3B (R=8/12) and profile 2B (R=8/14). Both profiles guarantee a bit-error-rate of less than 10^{-3} at a signal-to-noise-ratio of 11.5 dB and 9.8 dB, respectively for the DAB Hilly-Terrain-II profile at a Doppler frequency of 40 Hz (Mode II) [8]. A comparison of the simulation results with theoretical results (upper bounds) show a close match (<0.5 dB) for bit-error rates of less than 5×10^{-2} [8], assuming perfect interleaving. Furthermore, these analytical results are almost independent of the profile, as long as the maximum delay spread is smaller than the guard interval. Therefore, theoretical results for DAB transmission mode II ($f_0=1.5$ GHz), DAB HT 2 profile and various Doppler frequencies are shown in Figure 3.3-3.7 ($f_d=27, 40, 53, 97, 193$ Hz, speeds of 20, 30, 40, 70, 140 km/h). The results can easily be used for transmission mode I ($f_0=250$ MHz), which corresponds to 1/4 the Doppler frequency (longer symbol time) and 1/6 of the carrier frequency, thus leading to 1.5 times the speed of mode II.

Furthermore, the theoretical results for DAB HT II and COST typical hilly terrain (P4 of the DVB-T simulations) are directly comparable for the Doppler frequencies shown in Figure 3.3-3.7 [4]. The performance degradation in transmission mode II for DAB HT I

(P5 of the DVB-T simulations) is approximately 1-2 dB compared to DAB HT II due to longer echoes than the guard interval can handle (see: Guard Interval).

The simulation results were performed for the critical transmission mode II (L-Band) only. The behaviour for transmission mode I is clearly much better since much longer echoes can be tolerated.

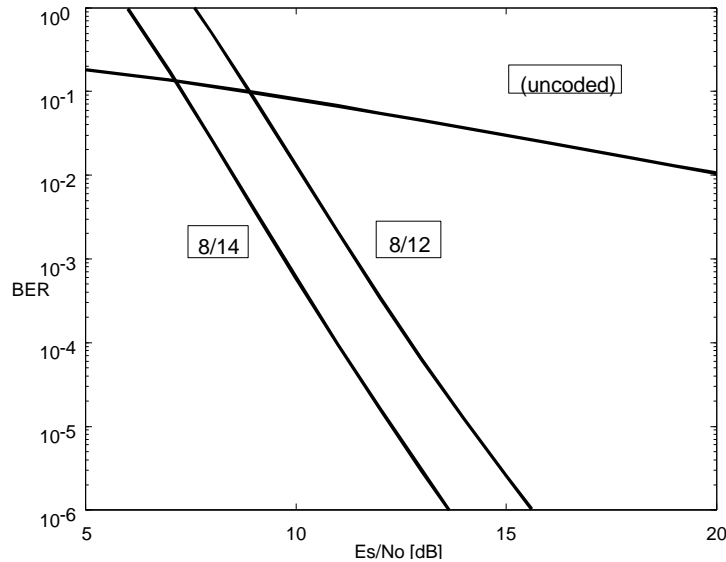

Figure 3.3: Theoretical results for TM II ($f_0=1.5$ GHz), code-rate 4/7 and 2/3, DAB HT 2, $f_d=27$ Hz.

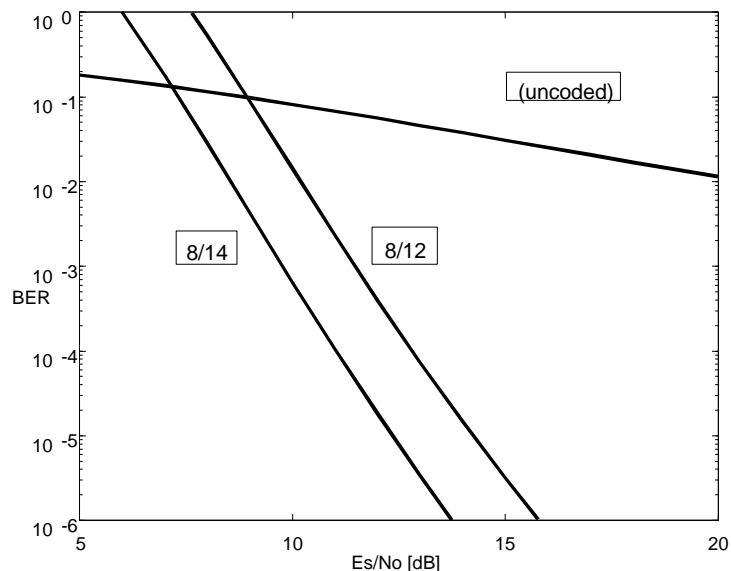

Figure 3.4: Theoretical results for TM II ($f_0=1.5$ GHz), code-rate 4/7 and 2/3, DAB HT 2, $f_d=40$ Hz.

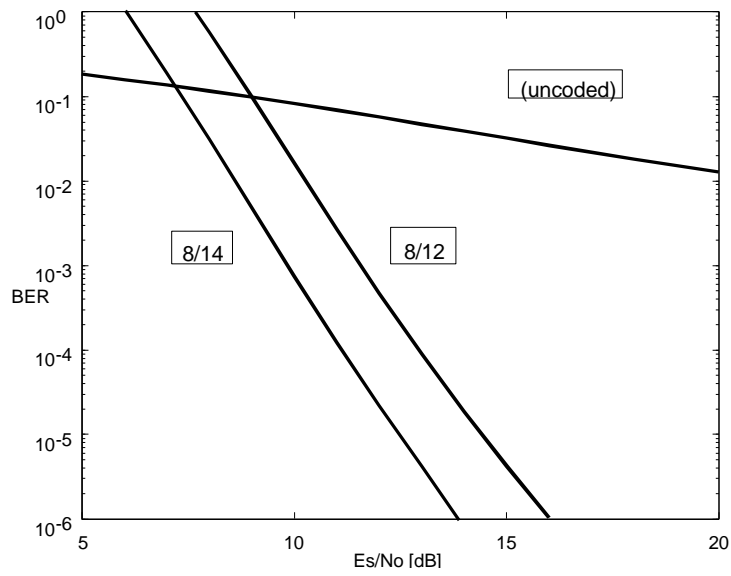

Figure 3.5: Theoretical results for TM II ($f_0=1.5$ GHz), code-rate 4/7 and 2/3, DAB HT 2, $f_d=53$ Hz.

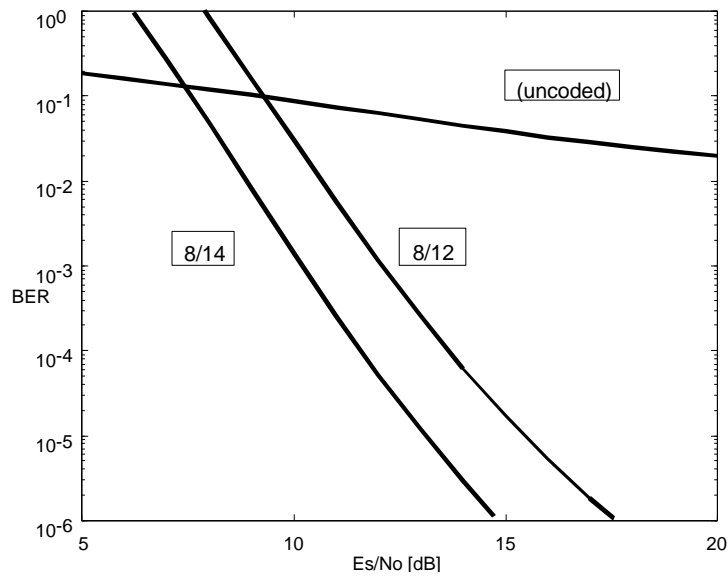

Figure 3.6: Theoretical results for TM II ($f_0=1.5$ GHz), code-rate 4/7 and 2/3, DAB HT 2, $f_d=97$ Hz.

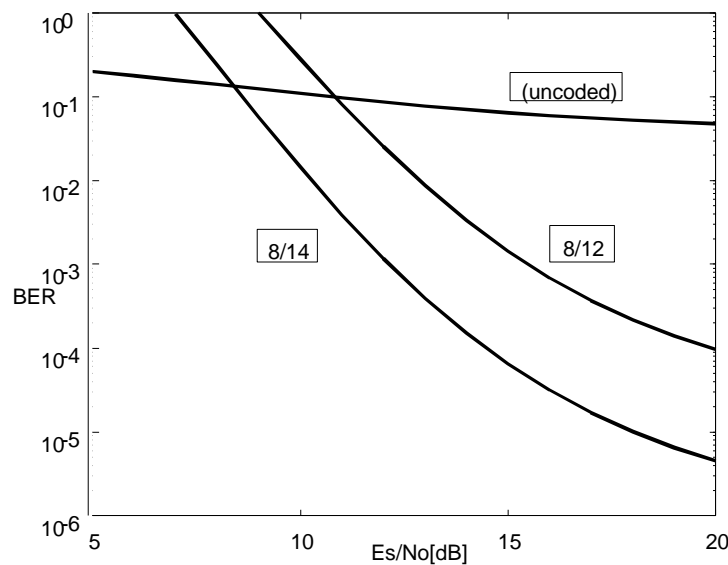

Figure 3.7: Theoretical results for TM II ($f_o=1.5$ GHz), code-rate 4/7 and 2/3, DAB HT 2, $f_d=193$ Hz.

3.5 System Discussion

3.5.1 Guard Interval:

DAB/DMB has different guard intervals, depending on the transmission modes, which enables one to match the transmission mode to the duration of the echoes. One estimates the maximum echo delay to be less or equal to $1.2 T_g$ without major system degradation's [4]. Simulation results [8] for DAB HT 1, Mode II, (i.e., 17 % of the energy is in an echo of $80 \mu s$, which is larger than the guard interval of $62 \mu s$) show that the system can cope quite well with inter-symbol interference (loss of orthogonality). A system degradation of only 1-2 dB (comparable to those caused by high speeds) occur.

3.5.2 Frequency Interleaving:

DMB/DAB performs frequency interleaving, using a permutation mechanism for the different carriers. Frequency interleaving is useful, if a fade does not affect the overall bandwidth of 1.5 MHz, but has several small (in frequency) fades and therefore also leaves some carriers without deep fades. This is guaranteed, if $B \times \Delta\tau \gg 1$, with $B=1.5$ MHz and $\Delta\tau$ the delay spread. In case of large delay spreads ($\Delta\tau=14\mu s$ for DAB HT 2, Mode II), this condition is fulfilled. For smaller delay spreads ($\Delta\tau=1 \mu s$, Typical Urban, TU) small performance degradation's occur (0.2 dB, $f_d=40$ Hz, Mode II, 225 MHz) [8]. These degradations increase, if the Doppler frequency gets smaller and time interleaving becomes more and more ineffective (see time interleaving), but leaving enough margin for operation under normal reception conditions.

3.5.3 Time Interleaving:

DAB/DMB employs a time interleaving, where 16 frames have to be stored (24 ms each) and are interleaved. Each frame is delayed by $n \times 24ms$ (with $n=0,1,\dots,15$). Therefore, time interleaving is effective, if the correlation time of the channel is less than 24ms ($f_d \times$

24ms > 1 or approximately $f_d > 40$ Hz). Time interleaving is independent of the transmission mode. Only in Mode I, the maximum Doppler frequency (fast fading) is 40 Hz, thus time interleaving is not working properly, for slow speeds it is even ineffective. Therefore, frequency interleaving becomes very important. On the other hand, short echoes are possible (problem for frequency interleaving), but long artificial echoes can be supplied by using a SFN. Simulation results for Mode II, 225 MHz and a low Doppler frequency of 10 Hz show a system degradation of 1-2 dB when comparing DAB HT 2 (long echoes) and TU (short echoes) [8].

3.5.4 Synchronisation:

In case of a signal degradation, the digital (audio or video) signal is lost first. If the signal further degrades, or if the measured bit-error rate is too high for a long time, the fine synchronisation gets more and more unreliable before the synchronisation process has to be started again. The receiver can handle a signal interruption of several 10s of seconds, without having to re-synchronise (receiver maintains and corrects possible time and frequency drift).

In case of a complete restart of the synchronisation, it takes 1 frame (1.5 frames in worst case) for coarse time synchronisation using the null-symbol and another 2 frames (worst case) for fine time and frequency synchronisation (using the TFPR symbol).

After 3 frames (288 ms (Mode I), 72 ms (Mode II)) the decoding process of the video and audio data can be started. In addition to the DVB-T/DMB specific delays of the outer interleaver, the Reed-Solomon decoder the Viterbi-Decoder and the source decoder, DMB has an additional delay due to time de-interleaving (16 audio frames of 24 ms = 384 ms) assuming parallel FIC decoding.

4 Discussion of Results

A comprehensive comparison of the DVB-T and DMB systems for mobile applications is not possible without extensive field trials, laboratory measurements and analysis. In this paper we have focused only on some of the topics that are relevant for assessment of the suitability of the DVB-T specifications. It is widely known that DMB was designed for and operates in mobile environments, but similar laboratory measurements and field trials (as for DVB-T) were not available for DMB, which would be needed in order to allow a direct comparison. In this section we shall summarise the findings that were presented in earlier sections.

In all our work we have assumed that the DVB-T specifications are not modified. We have only considered receiver specific design criteria which can be optimised for mobile reception.

- **Time Interleaving:** The simulation results show that especially channels with very short echo delays result in a strong variation of the received signal energy. This effect leads to an additional performance loss of up to 6.5 dB, which is not neglectable. A time interleaving would help to mitigate the effects of short and deep fades that, in addition, might be caused through obstructions (shadowing) due to the environment, especially in urban environments (bridges, signs, buildings, etc.). The DMB system includes such time interleaving which makes it very robust. However, time interleaving has disadvantages: increased system latency (delay), greater acquisition after the signal is lost.
- **Frequency Bandwidth:** The presence of a frequency interleaver allow both systems (DMB and DVB-T) to benefit from the frequency diversity. However, the DVB-T signal has a bandwidth that is about 5 times larger than that of DMB. It has been noticed that this alone results in lower fluctuation of the total received power for DVB-T, in contrast to DMB. Hence, DVB-T may provide more frequency diversity than DMB. This may partly compensate the lack of time interleaving of the former system.
- **Synchronisation:** Both systems appear robust as far as synchronisation (time, frequency, common phase) is concerned. Both need a few frames to re-synchronize after a long sync-loss period (shorter periods up to several frames might be bridged by special measures in the receiver). Moreover, the DVB-T standard foresees pilots in every symbol, and is perhaps faster to re-synchronise in the case of timing (OFDM symbol) or frequency sync loss [9].
- **Channel Estimation:** DMB does not need channel estimation and being simpler to design, since it is differentially encoded. However, DVB-T needs channel estimation for all modes, and as is commonly known, if channel estimation is done correctly, it may outperform incoherent detection. But, channel estimation will not be perfect, especially in mobile environments, and will result in an estimation error that will increase the BER. We have observed that the theoretical degradation can be about 3 dB even for high speeds (at least 240 km/h), when well designed filters are used for

channel estimation. The reason for this low sensitivity against Doppler is due to the high concentration and good distribution of pilots in the OFDM grid. However, it should be noticed that the above SNR-degradation figures can not be translated directly to the SNR-loss for a given BER. In addition, in the case of non optimal filtering (such as the case of the 2. dTTb demonstrator), the SNR- loss can be much higher. This fact is supported both by simulations and practical measurements. The receiver used in the measurements has the characteristic of showing a marked degradation when going from zero Doppler to a small (2 Hz, e.g.) Doppler frequency; this is due to a filter used in this particular receiver to combat CCI, and is not necessarily representative of what can be achieved in other receivers. Furthermore, the results of laboratories tests with the DVB-T specifications have shown that the Doppler frequency does not limit the mobile reception in the case of QPSK mode with a code rate of 1/2. It may seem that a mobile reception with a 16-QAM modulation -at the expense of a higher SNR- would be also possible by using an inner convolutional code with rate 1/2 that allows one to transmit a higher data rate of about 9.95 Mbit/s..

- **Subjective Tests, Error Concealment:** It has been found that a BER of $2 \cdot 10^{-4}$ after Viterbi decoding may not be needed for a subjective high quality video for mobiles. The actual BER can be up to 5 times as high ($1 \cdot 10^{-3}$), which can result in a SNR margin improvement of up to 3 dB. This is because the errors are highly correlated after Viterbi decoding (which is the best kind of error structure for RS decoding). In the case of longer bursts (both for DMB and DVB-T) post processing techniques such as error concealment are possible and promise a great improvement of subjective quality [10]. It remains to be seen whether error concealment can compensate the lack of time interleaving in DVB-T.
- **Power:** Using a subjective criterion, which gives approximately 3 dB better results than an objective criterion, one can obtain the following results to estimate the required power and data rates that can be transmitted in an 8 MHz UHF channel:
For the QPSK, a SNR of 11.4-12.4 dB (relatively same figures as DMB [6]) to allow a data rate of 4.98 Mbit/s is needed. A 7 dB stronger transmitter power is needed to double the data rate, i.e. a 16QAM requires a SNR of approx. 18-19 dB at 200 km/h. However, a 64-QAM modulation will require much higher transmitted power, i.e. SNR of about 27-30 dB to transmit 14.93 Mbit/s.
Furthermore, one has to keep in mind that the subjective criterion sometimes enables one to give an SNR-figure where an objective method would indicate a system failure, since the BER has an error floor and will not reach the required BER of $2 \cdot 10^{-4}$ (see simulation results).
- **Guard interval:** For the simulations of the DVB-T system, a guard interval of $T_G = T_s/4 = 56 \mu s$ (in 2K mode) was used. Approaching T_G , the DVB-T system, using a receiver that was not optimised for mobile reception, shows a rapid system failure at $0.93 T_G$. The DMB system, on the other hand, tolerates echoes up to $1.2 T_G$. In bad situations (hilly terrain), long echoes occur that can cause severe ISI and ICI and thus a rapid system failure. Therefore and in case of SFNs, the 8K mode has to be used for DVB-T, which on the other hand reduces the maximum Doppler shift the system

can handle. DMB tolerates longer echoes (with respect to T_G) and also has modes to cope with long echoes in large SFNs.

5 Conclusions

In this report, we have investigated the suitability of the DMB and DVB-T systems for mobile reception of digital video. We have employed theoretical analysis, simulation, laboratory measurements and field trials to assess the systems' performance. It has to be noted that DMB was carefully designed for mobile reception, and consequently works well in this environment. DVB-T, although not specifically designed for mobile reception, appears to work here also.

Further work is needed to assess the suitability of DVB-T for higher order modulation (e.g. 16 QAM with low inner code rate) in mobile environments, where simulations for the P4 profile (GSM, typical hilly terrain) and 16 QAM show a system failure for high Doppler frequencies. However, receiver designers should tune their algorithms to high speed synchronisation, optimal channel estimation, and error concealment if necessary. Sufficient field trials will be needed to determine the power necessary to achieve a given coverage area. It seems that the Doppler shift, especially for a QPSK constellation is not the fundamental limitation of DVB-T, as often believed. Rather, it is the lack of time interleaving that causes problems in the case of certain simulated channel profiles. Furthermore, it should be noted that in case of long echoes (SFN), to avoid ISI and ICI effects due to a short guard interval, the 8K mode has to be used, which reduces the tolerable Doppler shifts, i.e. tolerable vehicle speed by a factor of 4.

Therefore, comparing to other systems such as DMB, which has proven to be functional in all mobile environments at speed up to 250 km/h and large SFN, the DVB-T has some disadvantages in terms of long echo delay in 2k mode and maximum Doppler in 8k mode. For QPSK modulation the DVB-T provides the same spectral efficiency as DMB [6]. However, higher order of modulation (16- or 64-QAM) that allows one to transmit higher data rate will require higher transmitted power (7-8 dB higher in case of 16-QAM (speeds up to 200 km/h) and 14-18 dB higher in case of 64-QAM (speeds up to 160 km/h)), compared with the QPSK case. Nevertheless, it has been shown that the channel estimation of DVB-T is highly efficient and some potential for improvements in the mobile environments exist, especially in light of the fact that the receiver used for the field trials and laboratory tests was optimised for fixed reception with CCI disturbances.

6 List of Abbreviations

BER	Bit Error Rate
CIF	Common Interleaved Frame
DAB	Digital Audio Broadcasting
DMB	Digital Multimedia Broadcasting
DVB	Digital Video Broadcasting
DVB-T	Digital Terrestrial Video Broadcasting
ETSI	European Telecommunication Standards Institute
MPEG	Moving Picture Expert Group
MSE	Mean Square Error
RS	Reed-Solomon
TFSC	Task-Force on System Comparison (DVB)
TPS	Transmission Parameter Signalling
UHF	Ultra High Frequency
VHF	Very High Frequency

7 References

- [1] ETSI DVB-T-Specifications, Draft prETS 300 744, September 1996.
- [2] ETSI DAB-Specifications, Draft prETS 300 401, January 1997, ETSI.
- [3] J. Hallier, T. Lauterbach, M. Unbehaun, "Bild und Videouebertragung ueber DAB- Ein erster Schritt zum Multimedia-Rundfunk", in ITG Report 1994.
- [4] T. Lauterbach, "Digital Audio Broadcasting", Chapt. 10.5.4., Prototypsystem zur TV Uebertragung ueber das DAB-System, Franzis Edition, Feldkirchen, 1996
- [5] H. Schulz, G. Zimmermann, "A Compatible DAB Extension for Mobile Multimedia Applications", Proceedings of EPMCC'97, Bonn, Germany, September 1997
- [6] K. Fazel, S. Aign, A. Romanowski, M. J. Ruf, "Mobile Multimedia Services via DAB: DMB", Proc. IEEE Globecom'97 Conference, Phoenix, Nov. 1997.
- [7] P. Hoehner, S. Kaiser, P. Robertson, "Two Dimensional Pilot-Symbol-Aided Channel Estimation by Wiener Filtering", in Proceedings of IEEE ICASP'97 Conference, Munich, April 1997.
- [8] H. Schulze, "Digital Audio Broadcasting: Das Übertragungssystem im Mobilfunkkanal", Meschede Seminar, 19-21.9.1995
- [9] P. Robertson, "Close-to-optimal one shot frequency synchronisation for OFDM using pilot carriers", Proc. IEEE Globecom'97 (CTMC) conference, Phoenix, Nov. 1997
- [10] S. Aign S., K. Fazel, "Error detection and concealment measures in MPEG-2 video decoder," Proceedings of the International Workshop on HDTV'94, Oct. 94., Turin, Italy.

ANNEX I: QPSK Tests on Route 2 with different Attenuations

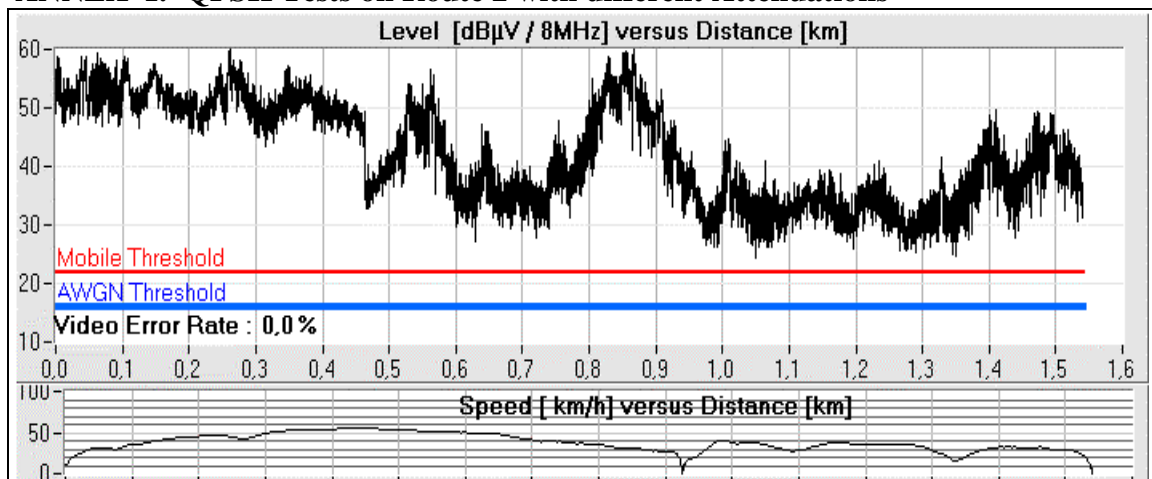

Figure I.1, Test without Attenuation

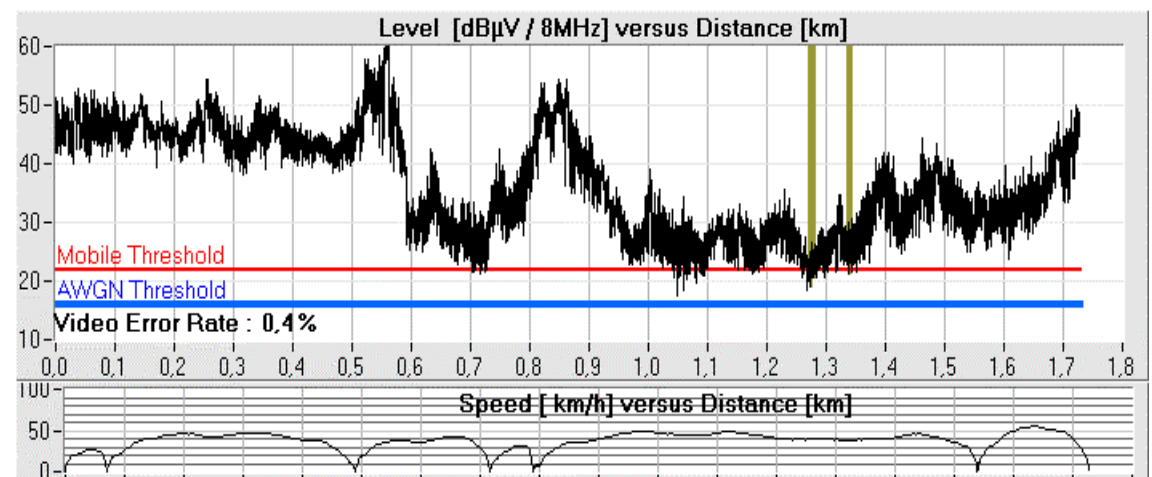

Figure I.2, Test with 6 dB Attenuation

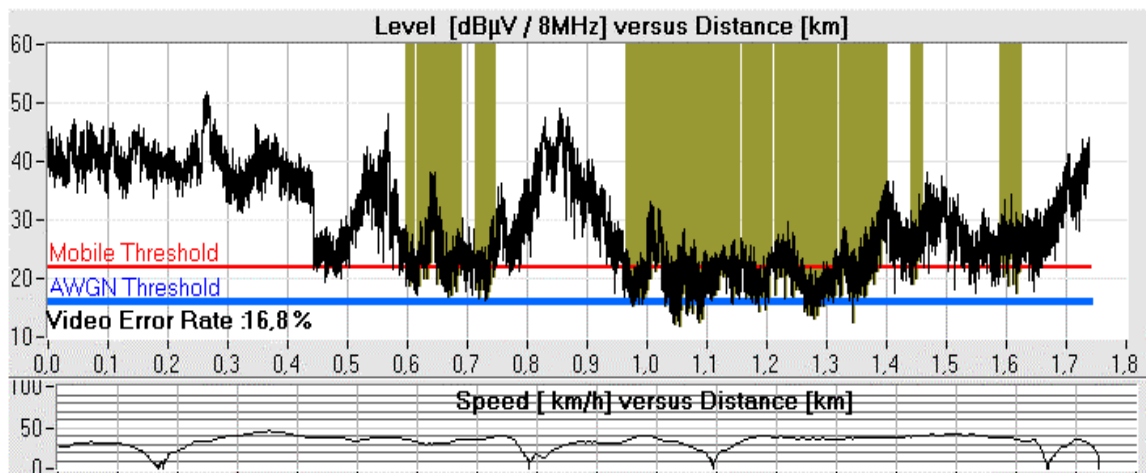

Figure I.3, Test with 12 dB Attenuation

ANNEX II : Test of different Constellations on two different Test Routes

